

1.5A/40V Input, 800kHz Synchronous Step-Down Converter

General Description

LN5016 is a current mode monolithic buck switching regulator. Operating with an input range of 4.5V~40V, the LN5016 delivers 1.5A of continuous output current with two integrated N-Channel MOSFETs. The internal synchronous power switches provide high efficiency without the use of an external Schottky diode. At light loads, the regulator operates in low frequency to maintain high efficiency and low output ripple. Current mode control provides tight load transient response and cycle-by-cycle current limit.

The LN5016 guarantees robustness with short-circuit protection, thermal protection, current run-away protection, and input under voltage lockout.

The LN5016 is available in 6-pin SOT23-6L package, which provides a compact solution with minimal external components.

Package

- SOT23-6L

Typical Application Circuit

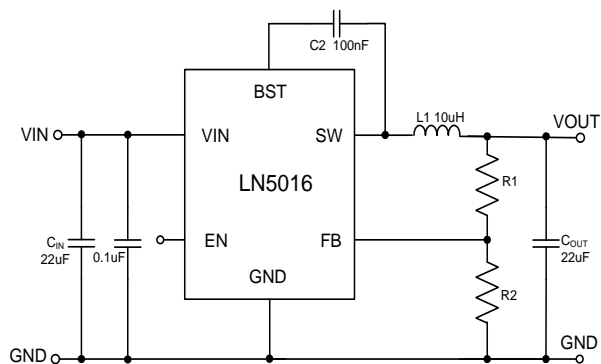

Features

- 4.5V to 40V Input Voltage Range
- 1.5A output current
- High Efficiency: Up to 95%
- No Schottky Diode Required
- 0.8V Reference
- Slope Compensated Current Mode Control for Excellent Line and Load Transient Response
- Integrated internal compensation
- Stable with Low ESR Ceramic Output Capacitors
- Input under voltage lockout
- Short circuit protection
- Thermal Shutdown
- Inrush Current Limit and Soft Start
- -40°C to +125°C Temperature Range

Applications

- Distributed Power Systems
- Automotive Systems
- High Voltage Power Conversion
- Industrial Power Systems
- Battery Powered Systems

Efficiency@VIN=12V

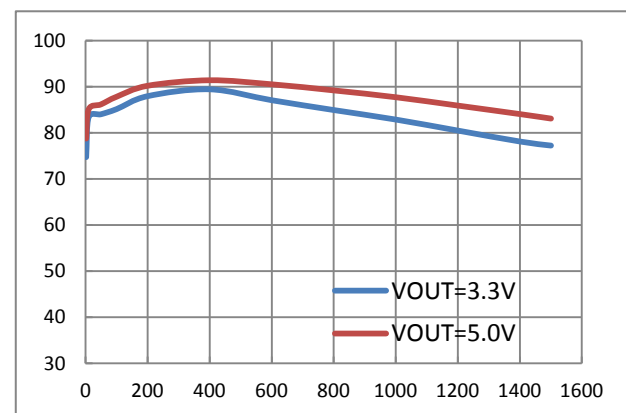

■ Ordering Information

LN5016P①②③-④

Designator	Symbol	Description
①	H	External feedback, Feedback Voltage 0.8V
②	M	Package Type :SOT-23-6L
③	R	Embossed Tape : Standard Feed
	L	Embossed Tape : Reverse Feed
④	G	Green epoxy molding compound

■ Pin Configuration

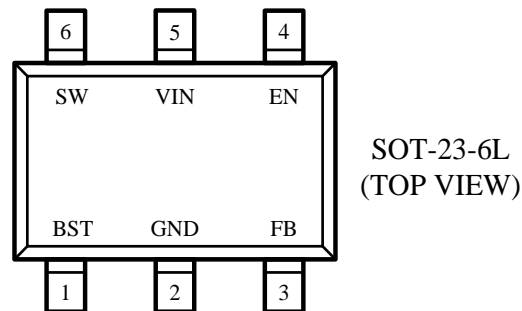

■ Pin Assignment

Pin Number	Pin Name	Function
SOT-23-6L		
1	BST	Bootstrap pin. Connect a 100nF capacitor from this pin to SW.
2	GND	Ground.
3	FB	Feedback Input. Connect an external resistor divider from the output to FB and GND to set VOUT.
4	EN	Enable pin for the IC. Drive this pin high to enable the part, low to disable.
5	VIN	Supply Voltage. Bypass with a 22 μ F ceramic capacitor to GND.
6	SW	Inductor Connection. Connect an inductor Between SW and the regulator output.

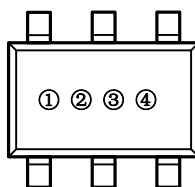
■ Marking Rule

 SOT-23-6L
 (TOP VIEW)

① Represents the product name

Symbol	Product Name
6	LN5016P***

② Represents the feedback voltage

Symbol	Description
H	Feedback Voltage 0.8V

③ Represents the packaging information

Symbol	Package
M	SOT23-6L

④ Represents the assembly lot No.

0-9, A-Z; 0-9, A-Z mirror writing, repeated (G, I, J, O, Q, W exception)

■ Absolute Maximum Ratings

Parameter	Symbol	Maximum Rating		Unit
Input Voltage	V_{IN}	$V_{SS}-0.3 \sim V_{SS}+45$		V
SW Voltage		$V_{SS}-0.3 \sim V_{IN}+0.3$		
BST Voltage		$V_{SW}-0.3 \sim V_{SW} +6$		
FB Voltage		$V_{SS}-0.3 \sim V_{SS}+6$		
EN Voltage		$V_{SS}-0.3 \sim V_{SS}+45$		
Power Dissipation	P_D	SOT-23-6L	300	mW
Thermal Resistance θ_{JC}	θ_{JC}	130		°C/W
Thermal Resistance θ_{JA}	θ_{JA}	170		°C/W
Operating Ambient Temperature	Topr	-40~125		°C
Storage Temperature	Tstg	-40~+150		
ESD HBM (Human Body Mode)		2		KV

Caution: The absolute maximum ratings are rated values exceeding which the product could suffer physical damage. These values must therefore not be exceeded under any conditions.

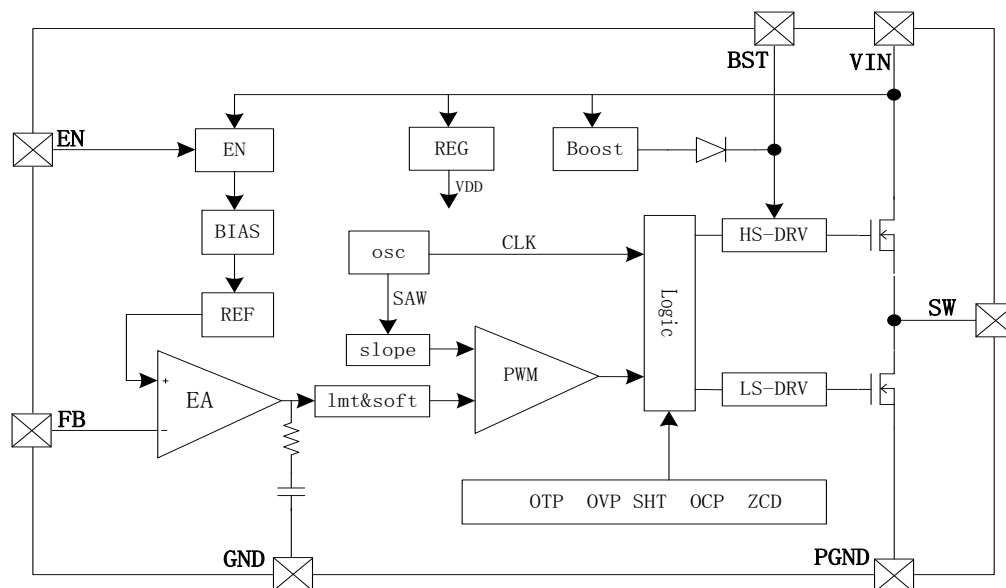
Function Block Diagram

Electrical Characteristics

Note: $V_{IN} = 12V$, $V_{OUT} = 5.0V$, unless otherwise specified. Typical values are at $T_A = 25^\circ C$

Parameter	Symbol	Condition	Min	Typ	Max	Unit
Input Voltage	V_{IN}		4.5		40	V
V_{IN} Under Voltage Protect	V_{UV}			4.3		V
V_{IN} Under Voltage Protect Hys.	V_{UV_hys}			0.2		V
Supply Current	I_{Q1}	$V_{EN}=2V, V_{FB}=0.85V$		40	60	μA
Supply Shutdown Current	I_{SD}		-1		1	μA
FB Voltage	V_{FB}	$T_A=25^\circ C, 4.5V \leq V_{IN} \leq 40V$	0.776	0.8	0.824	V
Switching Frequency	F_{OSC}			800		kHz
Minimum On Time	T_{ON_MIN}			200		ns
Maximum Duty Cycle	$DMAX$			90		%
High Side Switch On Resistance	R_{DSON_H}			450		m Ω
Low Side Switch On Resistance	R_{DSON_L}			270		m Ω
High Side Current Limit	I_{LIM}			2.5		A
EN Rising Threshold	V_{ENH}			1.3		V
EN Falling Threshold	V_{ENL}			1.2		V
EN Input Current	I_{EN}	$V_{EN}=5V$		2		μA
Thermal Shutdown	T_{SHD}			160		$^\circ C$
Thermal Shutdown Hys.	T_{SHD_Hys}			20		$^\circ C$

Typical Performance Characteristics (Vin=12V, Vout=5.0V, L=10uH, Cout=22uF, TA=+25°C)

Efficient @Vout=5.0V and 3.3V

CVIN=22uF, COUT=22uF, CBST=0.1uF LIND=10uH

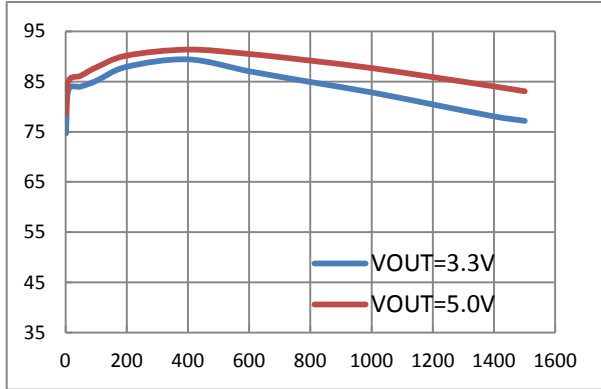

Max Load @Vout=3.3V and 5.0V

CVIN=22uF, COUT=22uF, CBST=0.1uF LIND=10uH

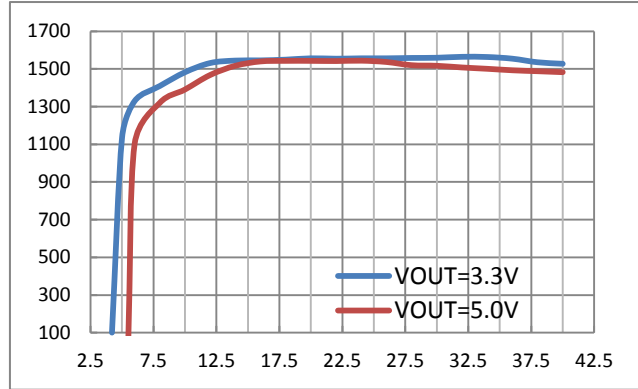

Steady State Test

Vin=12V, Vout=5.0V, Iout=800mA

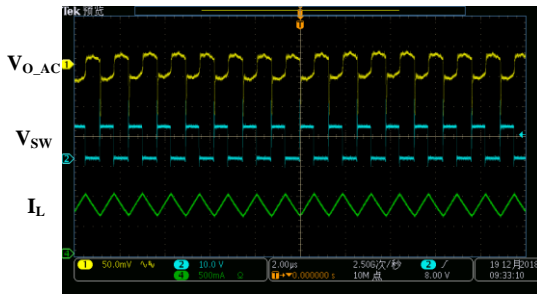

Light Load Operation

Vin=12V, Vout=5.0V, Iout=0A

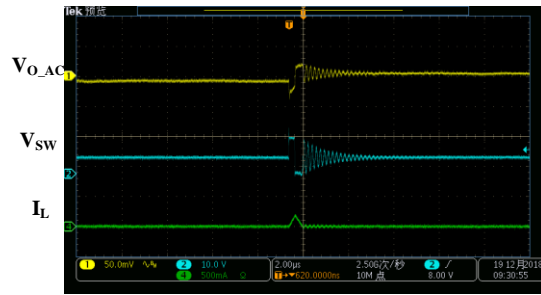

Medium Load Operation

Vin=12V, Vout=5.0V, Iout=400mA

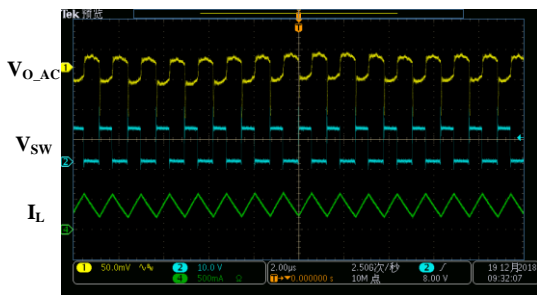

Startup through Enable

Vin=12V, Vout=5.0V, Iout=800mA (Resistive load)

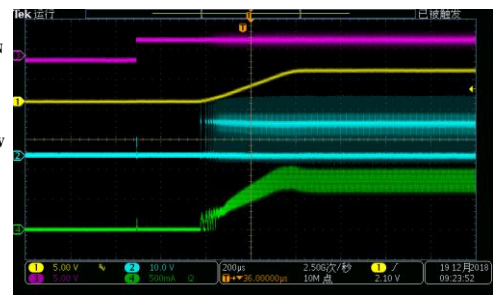

Shutdown through Enable

Vin=12V, Vout=5.0V, Iout=800mA (Resistive load)

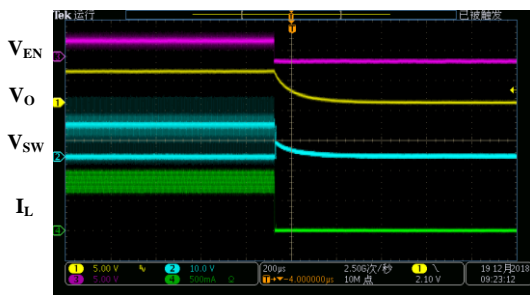

Load Transient

Load: 300mA ->800mA ->300mA

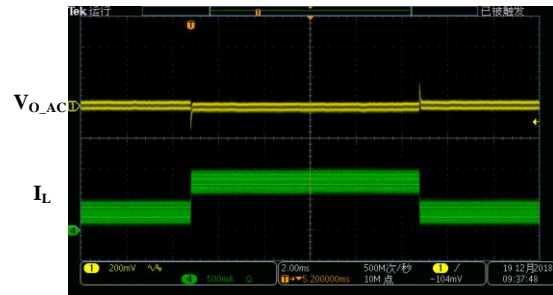

Short Circuit Protection

Vin=12V, Vout=5.0V, Lout=800mA - Short

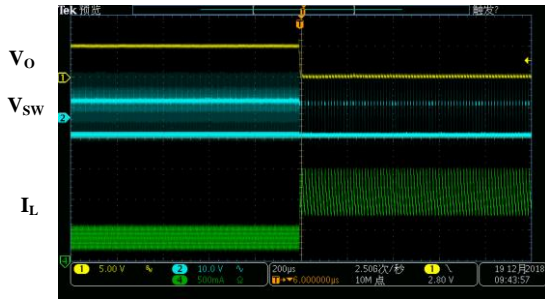
Short Circuit Protection

Vin=12V, Vout=5.0V, Lout= Short - 800mA

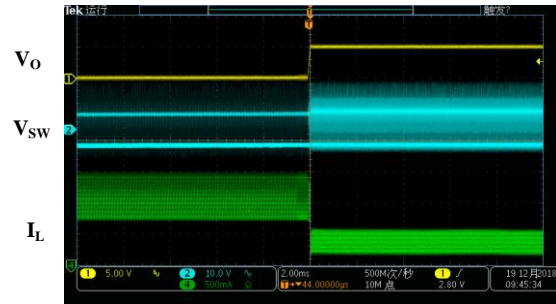

■ Functional Description

The LN5016 is a synchronous, current-mode, step-down regulator. It regulates input voltages from 4.5V to 40V, and is capable of supplying up to 1.5A of load current.

Current-Mode Control

The LN5016 utilizes current-mode control to regulate the output voltage. The output voltage is measured at the FB pin through a resistive voltage divider and the error is amplified by the internal trans-conductance error amplifier. Output of the internal error amplifier is compared with the switch current measured internally to control the output current.

PFM Mode

The LN5016 operates in PFM mode at light load. In PFM mode, switch frequency decreases when load current drops to boost power efficiency at light load by reducing switch-loss, while switch frequency increases when load current rises, minimizing output voltage ripples..

Shutdown Mode

The LN5016 shuts down when voltage at EN pin is below 0.3V. The entire regulator is off and the supply current consumed by the LN5016 drops below 0.1uA.

Power Switch

N-Channel MOSFET switches are integrated on the LN5016 to down convert the input voltage to the regulated output voltage. Since the top MOSFET needs a gate voltage great than the input voltage, a boost capacitor connected between BST and SW pins is required to drive the gate of the top switch. The boost capacitor is charged by the internal 4.0V rail when SW is low.

Vin Under Voltage Protection

A resistive divider can be connected between Vin and ground, with the central tap connected to EN, so that when Vin drops to the pre-set value, EN drops below 1.2V to trigger input under voltage lockout protection.

Over-Current-Protection and Hiccup

At start-up, due to the high voltage at input and low voltage at output, current inertia of the output inductance can be easily built up, resulting in a large start-up output current. In the LN5016 used current limit of low side power mosfet to control the output current at start-up.

Output Short Protection

When output is shorted to ground, output current rapidly reaches its peak current limit and the top power switch is turned off. And the bottom power switch is turned on and stay on until the output current falls below the current limit. When output current is below the current limit, the top power switch will be turned on again and if the output short is still present, the top power switch is turned off when the peak current limit is reached and the bottom power switch is turned on. This cycle goes on until the output short is removed and the regulator comes into normal operation again.

Thermal Protection

When the temperature of the LN5016 rises above 160°C, it is forced into thermal shut-down. Only when core temperature drops below 140°C can the regulator becomes active again

■ Application Information

Setting the Output Voltage

The external resistor divider is used to set the output voltage. Choose R1 and R2 follow the next table or calculated by following equation, where the internal reference voltage $V_{REF}=0.8V$.

$$\frac{R1}{R2} = \frac{V_{OUT} - V_{REF}}{V_{REF}}$$

$V_{OUT}(V)$	$R2(k\Omega)$	$R1(k\Omega)$
2.5	24	51
3.3	24	75
5.0	24	126

Inductor Selection

A 4.7μH to 22μH inductor with a DC current rating of at least 25% percent higher than the maximum load current is recommended for most applications. For highest efficiency, the inductor DC resistance should be less than 15mΩ. For most designs, the inductance value can be derived from the following equation.

$$L > \frac{V_{OUT} \times (V_{IN} - V_{OUT})}{V_{IN} \times \Delta I_L \times f_{OSC}} \quad \text{Where } \Delta I_L \text{ is the inductor ripple current.}$$

Choose ΔI_L to be approximately 30% of the maximum load current.

Under light load conditions below 100mA, larger inductance is recommended for improved efficiency.

Note: If the output voltage is less than 2.5V, it is recommended to use a larger inductance and add a small capacitance (10nF) parallel to R1.

Input Capacitor Selection

The input capacitor reduces the surge current drawn from the input and switching noise from the device. The input capacitor impedance at the switching frequency should be less than input source impedance to prevent high frequency switching current passing to the input. A low ESR input capacitor sized for maximum RMS current must be used. Ceramic capacitors with X5R or X7R dielectrics are highly recommended because of their low ESR and small temperature coefficients. A 22μF ceramic capacitor for most applications is sufficient. Include a capacitor with a value of 0.1 μF for high-frequency filtering and place it as close as possible to the device pins.

Output Capacitor Selection

The output capacitor (C_{OUT}) is required to maintain the DC output voltage, and the capacitance value determines the output ripple voltage. The output voltage ripple can be calculated by:

$$\Delta V_{OUT} = \frac{V_{OUT} \times (V_{IN} - V_{OUT})}{V_{IN} \times f_{OSC} \times L} \times \left(R_{ESR} + \frac{1}{8 \times f_{OSC} \times C_{OUT}} \right)$$

Where L is the inductor value and R_{ESR} is the equivalent series resistance (ESR) value of the output capacitor.

The output capacitor can be low ESR electrolytic, tantalum or ceramic, which lower ESR capacitors get lower output ripple voltage.

The characteristics of the output capacitor also affect the stability of the regulation system, and a 10uF ceramic capacitor is recommended in typical application. The LN5016 can be optimized for a wide range of capacitance and ESR values.

■ PCB Application Information

For minimum noise problem and best operating performance, the PCB is preferred to following the guidelines as reference.

1. Place the input decoupling capacitor as close to LN5016 (VIN pin and GND) as possible to eliminate noise at the input pin.
The loop area formed by input capacitor and GND must be minimized.
2. Put the feedback trace as far away from the inductor and noisy power traces as possible.
3. The ground plane on the PCB should be as large as possible for better heat dissipation.

■ Reference Design

Reference 1:

V_{IN} : 5.0V~40V

V_{OUT} : 3.3V

I_{OUT} : 0~1.5A

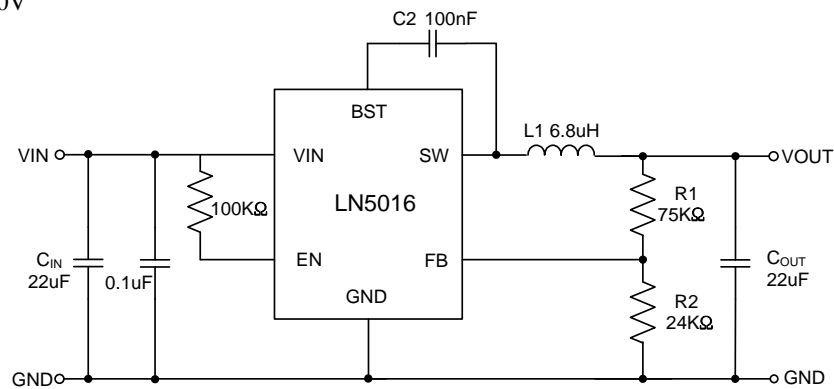

Reference 2:

V_{IN} : 6.5V~40V

V_{OUT} : 5.0V

I_{OUT} : 0~1.5A

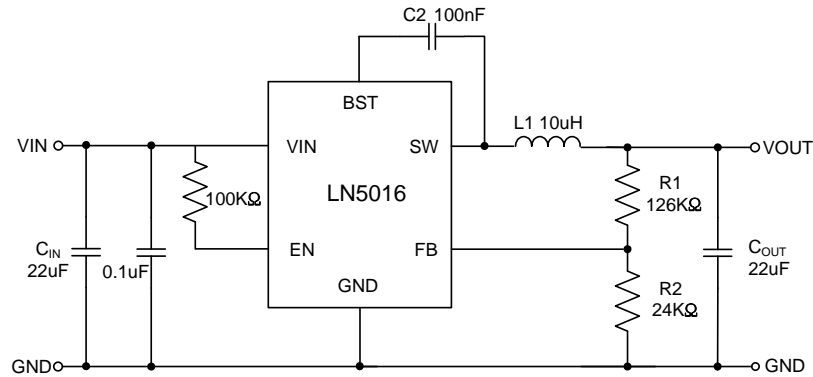

Package Information

- SOT-23-6L

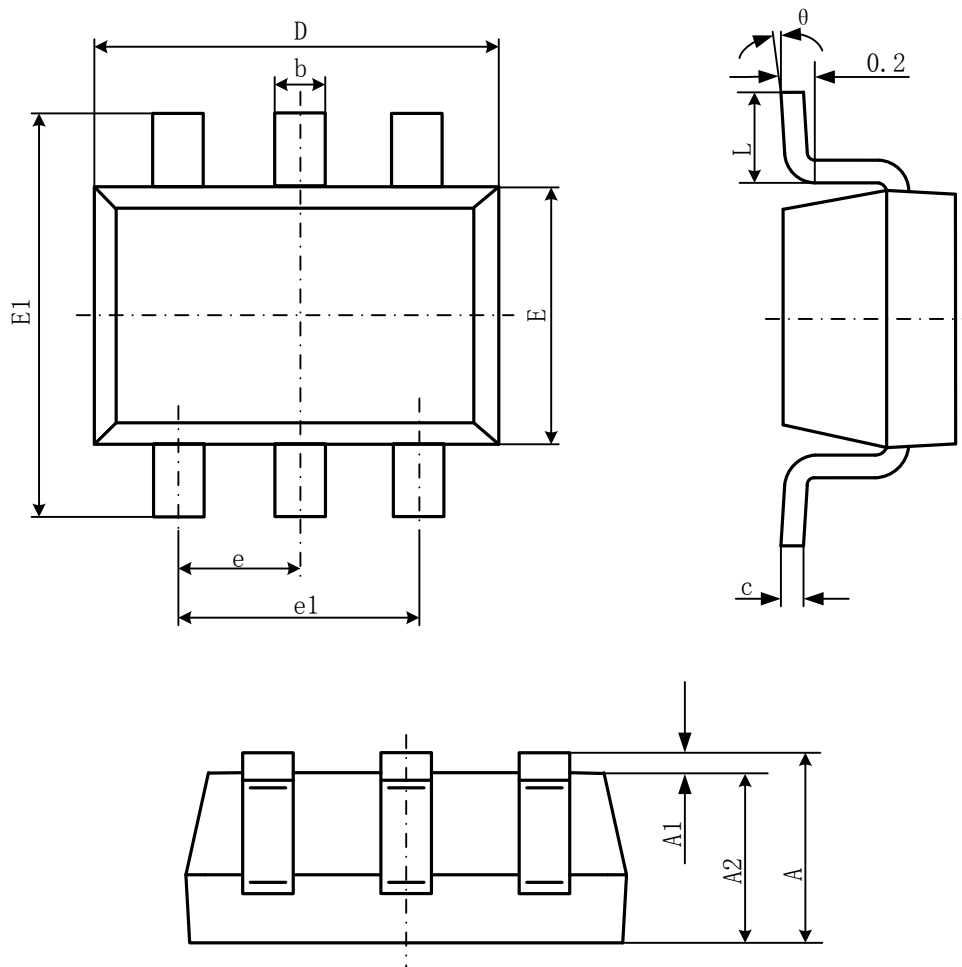

Symbol	Dimensions In Millimeters		Dimensions In Inches	
	Min	Max	Min	Max
A	1.050	1.250	0.041	0.049
A1	0.000	0.100	0.000	0.004
A2	1.050	1.150	0.041	0.045
b	0.300	0.500	0.012	0.020
c	0.100	0.200	0.004	0.008
D	2.820	3.020	0.111	0.119
E	1.500	1.700	0.059	0.067
E1	2.650	2.950	0.104	0.116
e	0.950(BSC)		0.037(BSC)	
e1	1.800	2.000	0.071	0.079
L	0.300	0.600	0.012	0.024
θ	0°	8°	0°	8°