

16V, 4.5A 高效升压转换器

16V, 4.5A Boost Converter

■ FEATURES

- Input voltage range: 2.6V to 5.5V
- Output voltage range: up to 16V
- Programmable switch peak current limit:
 - up to 3A (SOT23-6)
 - up to 4.5A (ESOP8)
- 0.1 μ A current consumption during shutdown
- Programmable soft start
- Output overvoltage protection (at 20V), thermal shutdown protection
- Pb-free Packages, SOT23-6, ESOP8
- 输入电压范围: 2.6V-5.5V
- 输出电压范围: 最高16V
- 可编程峰值电流: 3A (SOT23-6), 4.5A (ESOP8)
- 低关断功耗, 关断电流0.1 μ A
- 可编程软启动
- 输出过压 (20V)、热关断等保护
- SOT23-6, ESOP8无铅封装

■ APPLICATIONS

- Chargers
- LCD Displays
- 充电器
- LCD显示
- Digital Cameras
- Handheld Devices
- 数码相机
- 手持设备
- Portable Products
- 便携设备

ORDERING INFORMATION

Part Number	Package Type	Marking	Operating Temperature Range	Shipping Package / MOQ
HT7183STNR	SOT23-6 (STN)	71KYAA	-40°C~85°C	Tape and Reel (R) / 3000pcs
HT7183SPER	ESOP8 (SPE)	HT7183 YYMAAB ¹	-40°C~85°C	Tape and Reel (R) / 2500pcs

Part Number

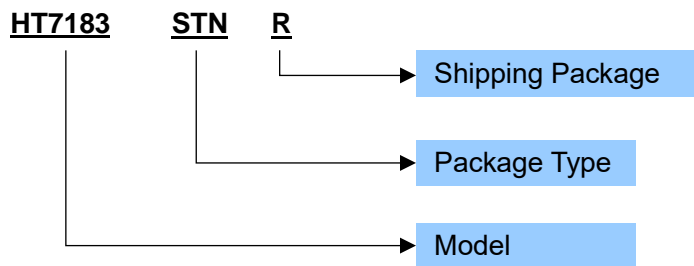

Marking

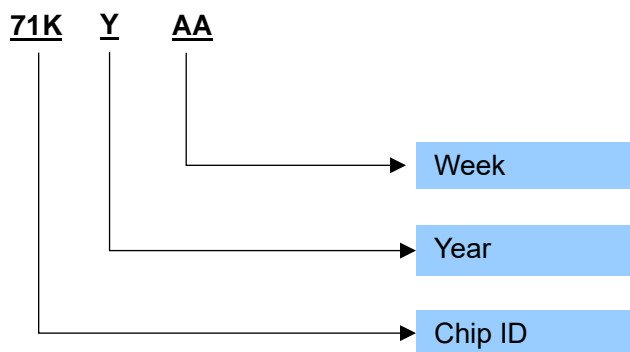

Production Tracking Code

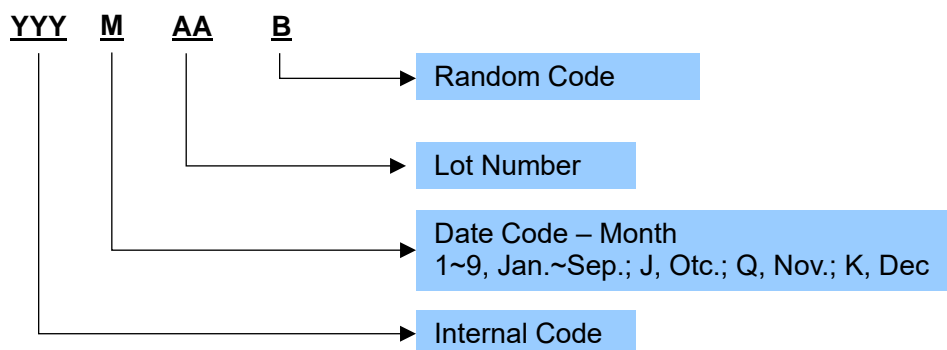

¹ YYMAAB is production tracking code
Copyright©2023, Heroic Technology

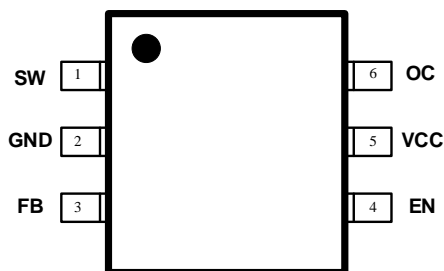
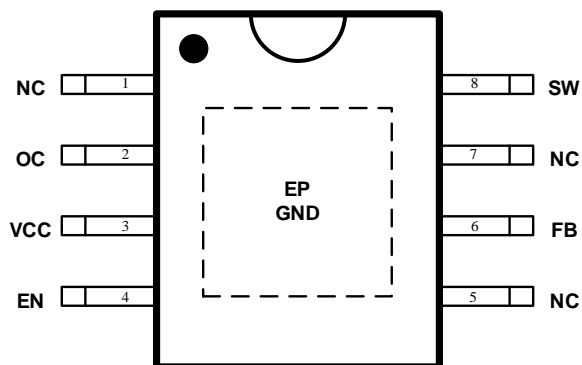
■ TERMINAL CONFIGURATION

SOT23-6 Top View

ESOP8 Top View
■ TERMINAL FUNCTION

Terminal No.		Name	I/O ¹	Description
SOT23-6	ESOP8			
1	8	SW	P	The switching node pin of the converter. 开关转换端
2	EP	GND	G	Ground.地
3	6	FB	I	Voltage feedback. 电压反馈
4	4	EN	I	Enable logic input. Logic high level enables the device. Logic low level disables the device and turns it into shutdown mode. 使能输入，高电平芯片工作；低电平芯片进入关断状态
5	3	VCC	P	Power supply. 电源供电
6	2	OC	I	Adjustable switch peak current limit. An external resistor should be connected between this pin and the GND pin. 峰值电流设置端，接电阻到地
-	1,5,7	NC	-	No connection, connect to GND.

¹ I: Input; O: Output; G: Ground; P: Power; BST: BOOT Strap; OD: Open drain

SPECIFICATIONS¹
Absolute Maximum Ratings²

PARAMETER		Symbol	MIN	MAX	UNIT
Voltage range	VCC	/	-0.3	6	V
	SW		-0.3	20	
	EN, FB		-0.3	6	
Operating temperature range		T _A	-40	85	°C
Operating junction temperature range		T _J	-40	150	°C
Storage temperature range		T _{STG}	-50	150	°C

Recommended Operating Conditions

PARAMETER	Symbol	CONDITION	MIN	TYP	MAX	UNIT
Supply voltage range	V _{CC}		2.6		5.5	V
Operating temperature	T _a		-40	25	85	°C
Operating junction temperature	T _J		-40		125	°C

Electrical Characteristics

Condition: T_a = 25°C, V_{IN} = 2.6V-5.5V, V_{OUT}=4.5-13.2V, unless otherwise specified.

Power Supply and Reference Voltage

PARAMETER	Symbol	CONDITION	MIN	TYP	MAX	UNIT
Power voltage range	VCC		2.6		5.5	V
Under-voltage lockout (UVLO) threshold	V _{UVLO}	Rising		2.4		V
		Falling		2.2		V
Quiescent current	I _Q	V _{FB} = 1.3V, No switching		0.3		mA
Shutdown current	I _{SD}	IC disabled, no load, no feedback resistor divider		0.1		µA
Reference voltage at the FB pin	V _{REF}			0.6		V
Output overvoltage protection	V _{OVP}			20		V

EN Input

PARAMETER	Symbol	CONDITION	MIN	TYP	MAX	UNIT
EN high threshold voltage	V _{ENH}		1.8			V
EN low threshold voltage	V _{ENL}				0.6	V
EN internal pull-down resistance	R _{EN}			800		kΩ

POWER SWITCH

PARAMETER	Symbol	CONDITION	MIN	TYP	MAX	UNIT
MOSFET on-resistance	R _{DS(on)}	Including wire bond		120		mΩ
Operation Frequency	F _{OSC}			800		kHz

CURRENT LIMIT

PARAMETER	Symbol	CONDITION	MIN	TYP	MAX	UNIT
Peak switch current limit	I _{LIM}	SOT23-6			3	A
		ESOP8			4.5	A

¹ Depending on parts and PCB layout, characteristics may be changed.

² Stresses beyond those listed under absolute maximum ratings may cause permanent damage to the device. These are stress ratings only, and functional operation of the device at these or any other conditions beyond those indicated under recommended operating conditions is not implied. Exposure to absolute-maximum-rated conditions for extended periods may affect device reliability.

THERMAL SHUTDOWN

PARAMETER	Symbol	CONDITION	MIN	TYP	MAX	UNIT
Thermal shutdown threshold	T _{SD}			150		°C
Thermal shutdown hysteresis	T _{SD_HYS}			20		°C

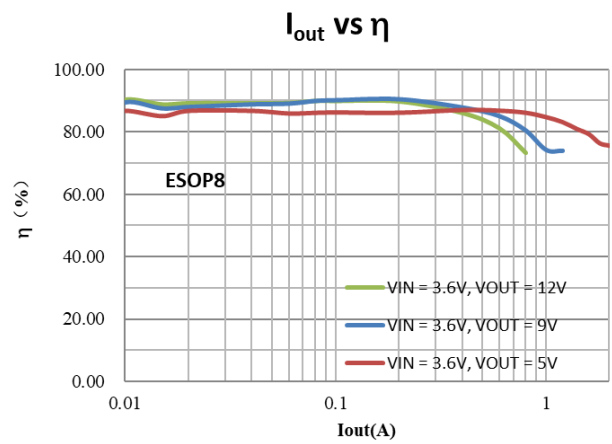
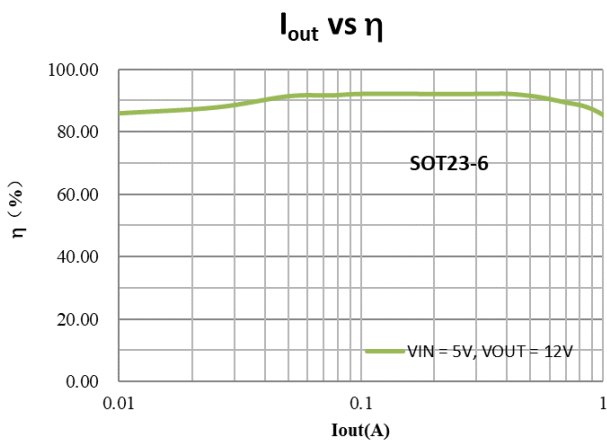
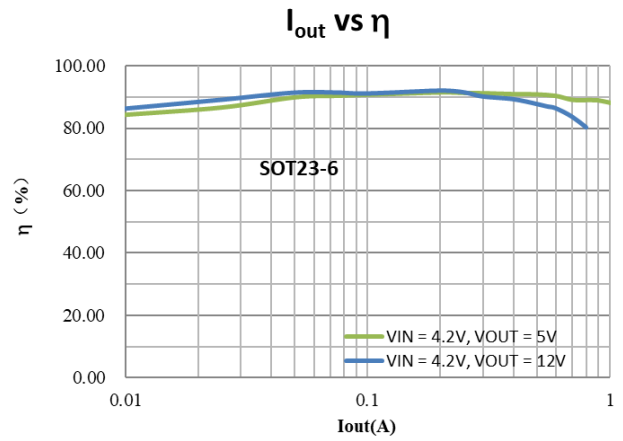
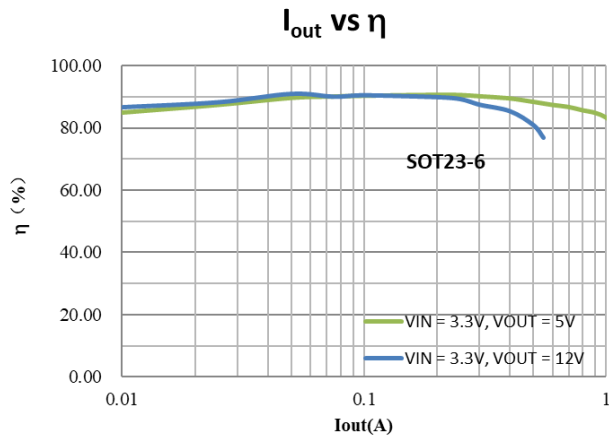
TYPICAL OPERATING CHARACTERISTICS

APPLICATION INFORMATION

1 Operation

The HT7183 is a high-power density, asynchronous boost converter with a 120mΩ power switch to provide a high efficiency and small size solution in portable systems. The switching frequency is around 800kHz. HT7183 operates with pulse width modulation (PWM), and improves the efficiency at light load with the pulse frequency modulation (PFM).

2 Enable and Soft Start Function

The HT7183 integrates soft start function to prevent high inrush current during start-up, and is charged with a constant current, slowly ramp up the internal positive input of the error amplifier.

When the EN pin is pulled into logic low (below 0.6V), the HT7183 goes into the shutdown mode and stops switching. Only when EN pin is pulled into logic high (above 1.8V), the HT7183 works.

3 Adjustable Peak Current Limit (OC pin)

To avoid an accidental large peak current, an internal cycle-by-cycle current limit is adopted. The low-side switch is turned off immediately as soon as the switch current touches the limit. The peak switch current limit can be set by a resistor (R_{OC}) at the OC pin to ground. The relationship between the current limit and the resistance is as the following figure. The current limit should be set lower than 3A for SOT23-6 or 4.5A for ESOP8.

HT7183 是一款高功率异步升压转换器，集成 120mΩ 功率开关管，为便携式系统提供高效的小尺寸解决方案。其开关频率约 800kHz。HT7183 工作在 PWM 模式，但在轻载时工作在 PFM 模式以提高工作效率。

HT7183 具有软启动功能，以防止芯片启动瞬间的大电流。

芯片的 EN 脚可控制芯片的开启与关断。EN 脚拉低，芯片进入关断模式，停止升压；EN 脚拉高，芯片进入升压工作模式。

为避免可能的突发性大电流尖峰，HT7183 内置了逐周期过流限制保护功能。一旦开关电流达到设定的峰值电流限流值，低端管立即关闭，以防止芯片大电流损坏。

峰值电流限流值可通过 OC 引脚接电阻 (R_{OC}) 至地设置，关系如下图。峰值电流限制值设置应小于 3A (SOT23-6) 或 4.5A (ESOP8)。

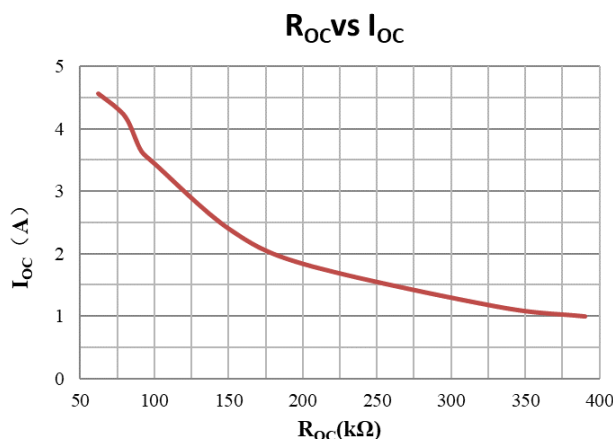

Figure 1 Peak Current Limit vs OC terminal resistor (R_{OC})

4 Output Voltage Setting (FB pin)

The output voltage is set by an external resistor divider (R_{UP} , R_{DN} in the Typical Application Circuit). To get the output voltage V_{OUT} , the Value of R_{UP} and R_{DN} can be calculated as:

输出电压值 V_{OUT} 可通过 FB 端的 R_{UP} , R_{DN} 电阻决定:

$$V_{OUT} = V_{REF} \times \left(1 + \frac{R_{UP}}{R_{DN}}\right)$$

Where $V_{REF} = 0.6V$.

其中 $V_{REF} = 0.6V$ 。

Some typical output voltages can be set as the following parameters

典型电压设置参数如下表。

Table 1 Output Voltage Settings

$V_{OUT}(V)$	$R_{UP}(\Omega)$	$R_{DN}(\Omega)$
5.1	510k	68k
9.1	510k	36k
12	510k	27k

5 Protection Function

5.1 Under-voltage Lockout (UVLO)

The UVLO circuit prevents the device from malfunctioning at low input voltage and the battery from excessive discharge. The HT7183 has VCC UVLO function. It disables the device from switching when the falling voltage at the VCC pin trips the UVLO threshold V_{UVLO} , which is typically 2.2V. The device starts operating when the rising voltage at the VCC pin is above the V_{UVLO} , which is typically 2.4V.

欠压锁定电路可防止低电压下电路的故障，以及输入端电阻的过放电。HT7183 的 VCC 端具有该功能。当电压低于相应阈值，芯片关闭。电压高于相应阈值，芯片开启。

5.2 Over-voltage Protection

If the output voltage is detected above 20 V (typical value), the HT7183 stops switching immediately until the voltage drops the hysteresis value lower than the output overvoltage protection threshold. This function prevents overvoltage on the output and secures the circuits connected to the output from excessive overvoltage.

如果输出电压高于 20V (典型值)，HT7183 停止工作，直至输出电压降低至低于阈值。

5.3 Thermal Shutdown

A thermal shutdown is implemented to prevent damages due to excessive heat and power dissipation. Typically, the thermal shutdown happens at a junction temperature of 150°C. When the thermal shutdown is triggered, the device stops switching until the junction temperature falls below typically 130°C, then the device starts switching again.

当芯片内部结温高于 150°C 时，过温关断保护启动，芯片停止工作，直至芯片内部结温降低至 130°C。该功能可有效防止芯片损坏。

6 Application Note

6.1 Inductor Selection

Because the selection of the inductor affects the power supply's steady state operation, transient behavior, loop stability, and boost converter efficiency, the inductor is the most important component in switching power regulator design. Three most important specifications to the performance of the inductor are the inductor value, DC resistance, and saturation current.

To be simplified, the inductor value can be set as 3.3uH to 4.7uH which can be used in most cases.

The rated current, especially the saturation current should be larger than the peak current during the whole operation. The peak current can be calculated as follows.

$$I_{Lpeak} = I_{DC} + \frac{I_{PP}}{2}$$

$$I_{DC} = \frac{V_{OUT} \times I_{OUT}}{V_{IN} \times \eta}$$

$$I_{PP} = \frac{1}{L \times \left(\frac{1}{V_{OUT} - V_{IN}} + \frac{1}{V_{IN}} \right) \times f_{SW}}$$

Boost converter efficiency is affected significantly by the inductor's DC resistance (DCR), equivalent series resistance (ESR) at the switching frequency, and the core loss. An inductor with lower DCR and ESR would increase the efficiency significantly.

The inductor should be placed as close as possible to the SW pin. For a lower EMI radiation, connecting a resistor and a capacitor in series to the ground would be helpful. 1ohm resistor and 3.3nF capacitor would be recommended in most cases

6.2 Output Capacitor Selection (C_{OUT})

Capacitors can lose most of their capacitance at rated voltage. Therefore, leave margin on the voltage rating to ensure adequate effective capacitance.

In detail, for the require output voltage ripple, use the following equations to calculate the minimum required effective capacitance C_{OUT} .

$$V_{ripple_dis} = \frac{(V_{OUT} - V_{INMIN}) \times I_{OUT}}{V_{OUT} \times f_{SW} \times C_{OUT}}$$

$$V_{ripple_ESR} = I_{Lpeak} \times R_{C_ESR}$$

电感的选择直接影响到电源的稳定,瞬态表现,环路稳定,升压转换效率,因此,电感是升压电路中最重要器件。其中,电感值、饱和电流、直流阻抗 DCR 为重要的选型指标。

对于电感值,简单来说,3.3uH 到 4.7uH 能满足大多数应用。

对于饱和电流,其应大于芯片所有工作条件下的最大电流峰值。最大电流峰值可通过如下计算。

升压转换效率受电感的DCR和高频时的ESR影响较大,所以选择较低的DCR和ESR能有效提升效率。

另外,电感在PCB Layout时,应紧靠SW脚。

最后,在SW端加入RC串联电路到地,能有效减小电路产生的EMI辐射。一般的, $R = 1\text{ohm}$, $C = 3.3\text{nF}$, 可满足应用。

需要注意的是,电容在额定电压下,容值损失严重,因此,电容的额定电压应留有余量的大于最大输出电压。

详细的,最低要求的电容值应满足以下条件:

Where

- $V_{\text{ripple_dis}}$ is output voltage ripple caused by charging and discharging of the output capacitor.
- $V_{\text{ripple_ESR}}$ is output voltage ripple caused by ESR of the output capacitor.
- $V_{\text{IN_MIN}}$ is the minimum input voltage of boost converter..
- V_{OUT} is the output voltage..
- I_{OUT} is the output current.
- I_{Lpeak} is the peak current of the inductor.
- f_{SW} is the converter switching frequency.
- $R_{\text{C_ESR}}$ is the ESR of the output capacitors.

6.3 Diode Selection

Schottky diode with fast recovery times and low forward voltages are recommended. Ensure the diode average and peak current rating exceed the average output current and peak inductor current. In addition, the diode's reverse breakdown voltage must exceed the output voltage.

6.4 Layout Considerations

As for all switching power supplies, especially those running at high switching frequency and high currents, layout is an important design step. If layout is not carefully done, the regulator could suffer from instability and noise problems.

- Use integral GND ground plane under the chip
- Minimize the length and area of all traces connected to the SW pin
- The power traces, consisting of the GND trace, the SW trace, the VIN trace and the VOUT trace should be kept short, direct and wide.
- The input capacitor needs to be close to inductor L and GND pin in order to reduce the input supply ripple. The output capacitor needs to be close to Diode and GND pin in order to reduce the output supply ripple.
- The resistor divider R_{UP} and R_{DN} must be connected to FB pin directly as closely as possible.
- The layout should also be done with well consideration of the thermal as this is a high-power density device. A thermal pad that improves the thermal capabilities of the package should be soldered to the large ground plate, using thermal vias underneath the thermal pad.

其中:

- $V_{\text{ripple_dis}}$ 是由输出电容充放电引起的输出电压纹波。
- $V_{\text{ripple_ESR}}$ 是由输出电容 ESR 引起的输出电压纹波。
- $V_{\text{IN_MIN}}$ 是最小输入电压。
- V_{OUT} 是输出电压。
- I_{OUT} 是输出电流。
- I_{Lpeak} 是电感的峰值电流。
- f_{SW} 是开关频率。
- $R_{\text{C_ESR}}$ 是输出电容的 ESR.

肖特基二极管应选择快恢复时间和低正向电压。应确保二极管的平均额定电流、峰值额定电流超过输出平均电流和电感峰值电流。此外，二极管的反向击穿电压应大于输出电压。

对于 DCDC 电源，特别是运行在大电流、高频率状态下，Layout 是非常关键的因素，不佳的 Layout 可能影响其工作的稳定。

- 芯片下面应尽量使用完整铺地。
- SW 走线尽量短，低阻抗。
- 电源走线，包括 GND、SW、VIN、VOUT，应尽可能短而粗。
- 输入电容应尽可能靠近相应引脚和器件（电感 L），并以低阻抗良好接地。若有条件，尽量选择 ESR 小的滤波电容，或者容值足够大，以提高开关管打开瞬间，给电感充电的能量。尤其是单节锂电池供电情况，若输入端纹波较大，可能造成芯片欠压保护。电源至电感、SW 的走线应尽可能短而低阻抗。

输出电容应尽可能靠近二极管，并以低阻抗良好接地。电源输出走线应尽可能短而低阻抗。滤波小电容尽量靠近二极管摆放，以降低 OUT 上的电压毛刺，以及降低 EMC 辐射。

- R_{UP} 和 R_{DN} 尽量靠近 FB 引脚。
- 芯片背部的散热片应良好接至 PCB 表面露铜的地，并通过过孔将热量传递至背面大面积地平面，以增加散热面积。

PACKAGE OUTLINE

STN (SOT23-6)

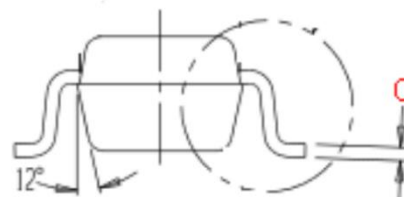
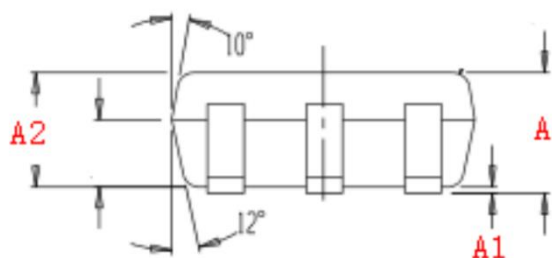
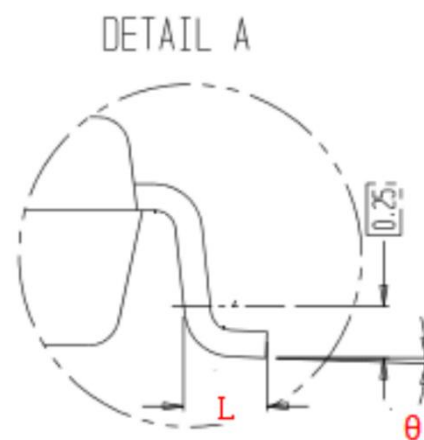
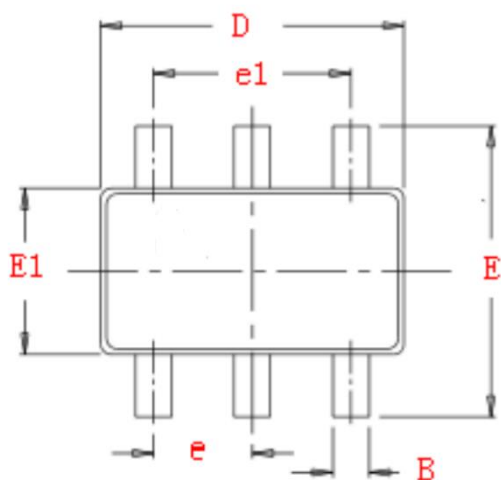

Symbol	Dimensions in Millimeters	
	Min.	Max.
A	1.06	1.26
A1	0.00	0.10
A2	1.00	1.20
C	0.13	
D	2.72	3.12
E	2.60	3.00
L	0.40	
B	0.30	0.50
e	0.95	
e1	1.90	
E1	1.40	1.80
θ	0°	10°

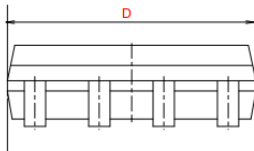
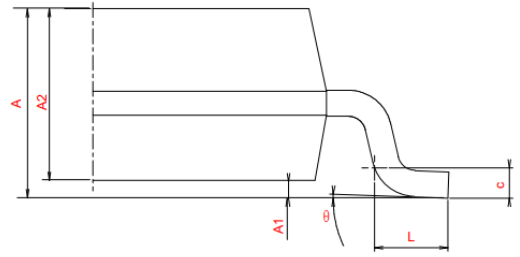
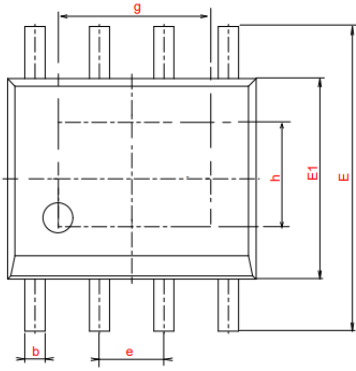
SPE (SOP8L-PP)

名称	尺寸	
	Min	Max
A	1.45	1.75
A1	0.05	0.15
A2	1.35	1.55
b	0.3	0.5
c	0.22	0.28
D	4.7	5.1
E	5.8	6.2
E1	3.85	4.05
L	0.4	1.27
θ	0°	8°
e	1.270 (BSC)	
h	2.4	
g	3.3	

TAPE AND REEL INFORMATION

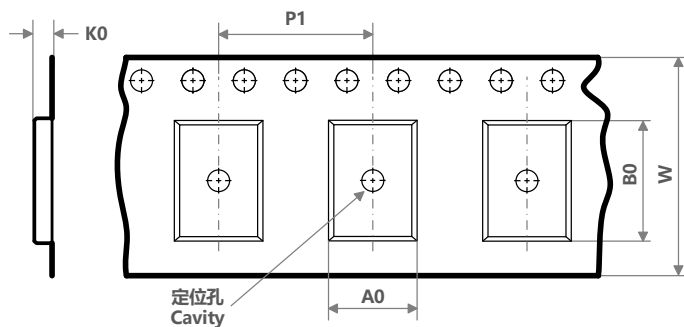
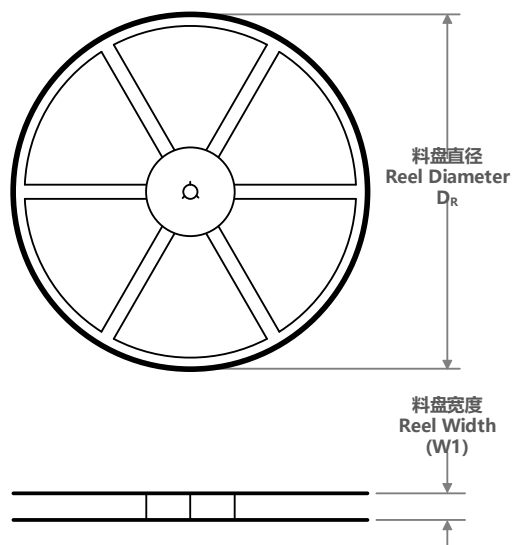

A0	Dimension designed to accommodate the component width; 料槽宽度
B0	Dimension designed to accommodate the component length; 料槽长度
K0	Dimension designed to accommodate the component thickness; 料槽厚度
W	Overall width of the carrier tape; 载带整体宽度
P1	Pitch between successive cavity centers; 相邻槽中心间距

编带 PIN1 方位象限分配
Quadrant Assignments for Pin1 Orientation in Tape

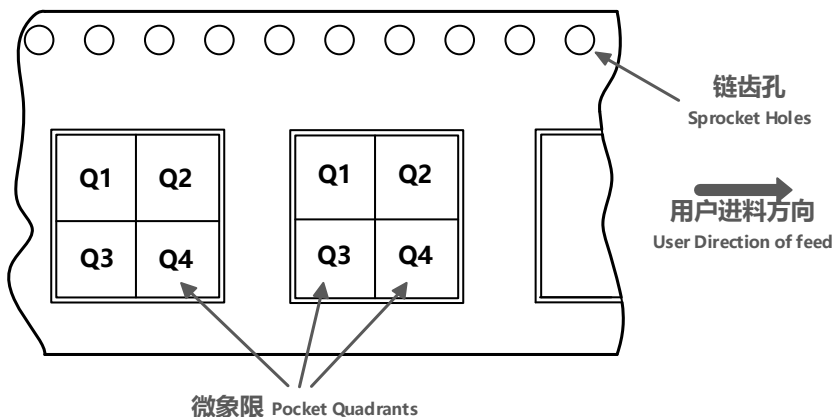

器件料号 Part No.	封装类型 Package Type	封装标识 Package Abbr.	引脚数 Pins	SPQ	料盘直径 D_R (mm)	料盘宽度 $W1$ (mm)	$A0$ (mm)	$B0$ (mm)	$K0$ (mm)	$P1$ (mm)	W (mm)	Pin1 象限 Quadrant
HT7183STNR	SOT23	STN	6	3000	TBD	TBD	TBD	TBD	TBD	TBD	TBD	Q1
HT7183SPER	ESOP	SPE	8	2500	TBD	TBD	TBD	TBD	TBD	TBD	TBD	Q1

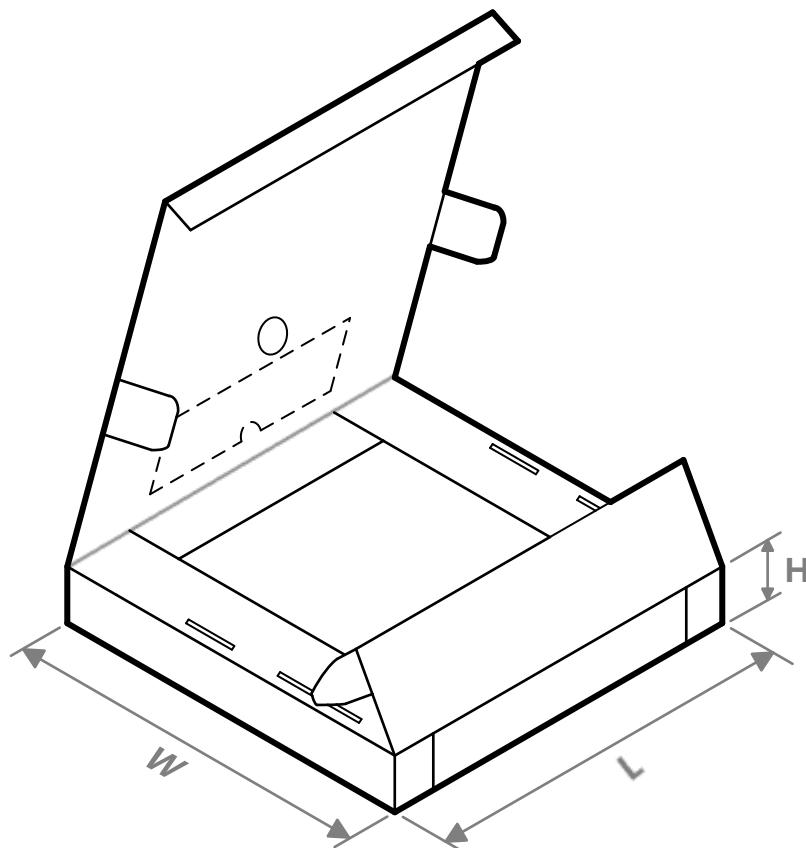
TAPE AND REEL BOX INFORMATION

器件料号 Part No.	封装类型 Package Type	封装标识 Package Abbr.	引脚数 Pins	SPQ	长度 Length (mm)	宽度 Width (mm)	高度 Height (mm)
HT7183STNR	SOT23	STN	6	TBD	TBD	TBD	TBD
HT7183SPER	ESOP	SPE	8	TBD	TBD	TBD	TBD

IMPORTANT NOTICE**注意**

Heroic Electronic Technology (Jiaxing) Co., Ltd (HT) reserves the right to make corrections, modifications, enhancements, improvements, and other changes to its products and services at any time and to discontinue any products or services. Customers should obtain the latest relevant information before placing orders and should verify that such information is current and complete.

禾润电子科技（嘉兴）股份有限公司（以下简称HT）保留对产品、服务、文档的任何修改、更正、提高、改善和其他改变，或停止提供任何产品和服务的权利。客户在下单和生产前应确保所得到的信息是最新、最完整的。

HT assumes no liability for applications assistance or customer product design. Customers are responsible for their products and applications using HT components.

HT对相关应用的说明和协助以及客户产品的板级设计不承担任何责任。

HT products are not authorized for use in safety-critical applications (such as life support devices or systems) where a failure of the HT product would reasonably be expected to affect the safety or effectiveness of that devices or systems.

HT的产品并未授权用于诸如生命维持设备等安全性极高的应用中。

The information included herein is believed to be accurate and reliable. However, HT assumes no responsibility for its use; nor for any infringement of patents or other rights of third parties which may result from its use.

本文中的相关信息是精确和可靠的，但HT并不对其负责，也不对任何可能的专利和第三方权利的侵害负责。

Following are URLs and contacts where you can obtain information or supports on any HT products and application solutions:

下面是可以联系到我公司的相关链接和联系方式：

禾润电子科技（嘉兴）股份有限公司
Heroic Electronic Technology (Jiaxing) Co., Ltd.

地址：浙江省嘉兴市凌公塘路3339号JRC大厦A座三层

Add: A 3rd floor, JRC Building, No. 3339, LingGongTang Road, Jiaxing, Zhejiang Province

Sales: 0573-82585539, sales@heroic.com.cn

Support: 0573-82586151, support@heroic.com.cn

Fax: 0573-82585078

Website: www.heroic.com.cn; wap.heroic.com.cn

Wechat MP: HEROIC_JX

请及时关注禾润官方微信公众号，随时获取最新产品信息和技术资料！

