

免电感滤波2×20W D类立体声音频功放

2×20W Inductor Free Class D Stereo Amplifier

■ FEATURES

- Output Power (BTL)
2×20W (VDD=14.5V, RL=4Ω, THD+N=1%)
 - Single Wide Voltage Supply: 4.5~20V
 - Efficiency > 90%
 - Differential / Single-ended Analog Input
 - Gain: 32dB
 - Spread Switching Frequency For Inductor Free
 - Integrated Self-protection Circuits Including Overvoltage, Undervoltage, Overtemperature, DC-detect, and Overcurrent with Error Reporting
 - LF and HF Package of ESOP16
- 输出功率 (BTL模式)
2×20W (VDD=14.5V, RL=4Ω, THD+N=1%)
 - 单电源系统: 4.5~20V
 - 超过90%效率, 无需散热器
 - 扩频功能, 免电感滤波
 - 模拟差分/单端输入可选
 - 增益: 32dB
 - 保护功能: 过压/过流/过热/欠压异常, 直流检测和短路保护
 - 无铅无卤封装, ESOP16

■ APPLICATIONS

- Sound Bars
- Consumer Audio Applications
- TVs/Monitors
- Wireless Speakers
- 条形音箱
- 便携式音箱
- 拉杆音箱
- 无线智能音箱
- 消费类音频应用
- LCD电视/视器监

■ DESCRIPTION

HT326C is a stereo efficient, Class-D audio amplifier for driving speakers up to 2×20W/4Ω power.

Advanced EMI Suppression with Spread Spectrum Control enables the use of inexpensive ferrite bead filters while meeting EMC requirements for system cost reduction.

HT326C is fully protected against faults with Overvoltage, Undervoltage, Overtemperature, DC-detect, and Overcurrent protection. Faults can be reported to the processor to prevent devices from being damaged.

HT326C是一款高效D类音频功率放大器。在14.5V供电的、THD+N=1%条件下, 能够持续提供2*20W/4Ω功率输出。

HT326C具有先进的扩频功能来抑制EMI, 使用价格低廉且小体积铁氧体磁珠可满足EMC要求。

此外, HT326C内置关断功能使待机电流最小化, 还集成了过压保护、直流保护、短路保护、热保护和电源欠压异常保护等功能, 可全面防止出现故障。

■ TYPICAL APPLICATION

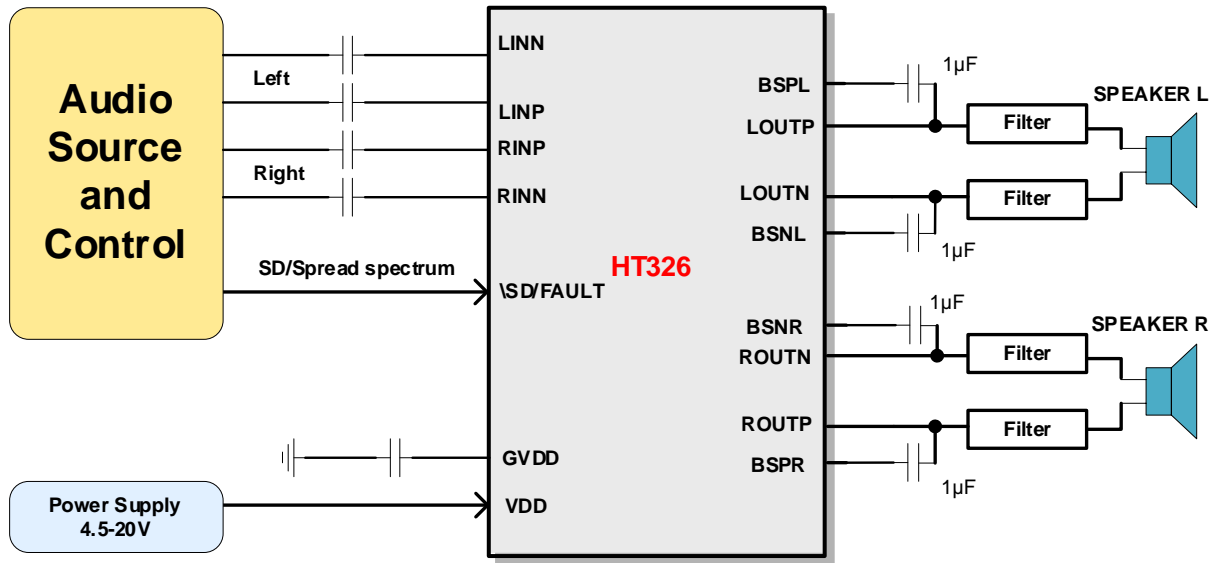

ORDERING INFORMATION

Part Number	Package Type	Marking	Shipping Package / MOQ
HT326CSPER	ESOP16 (SPE)	HT326C YYYMAAB ¹	Tape and Reel (R) / 2500pcs

Part Number

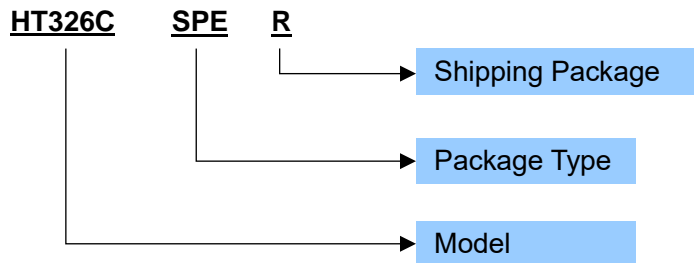

Production Tracking Code

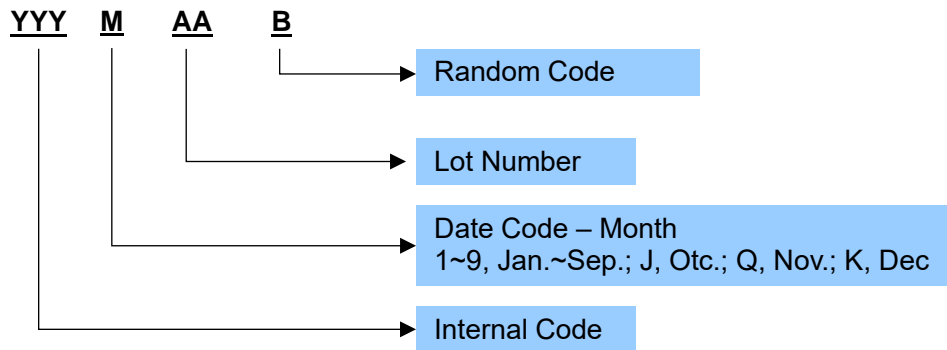

¹ YYYMAAB is production tracking code
Copyright©2023, Heroic Technology

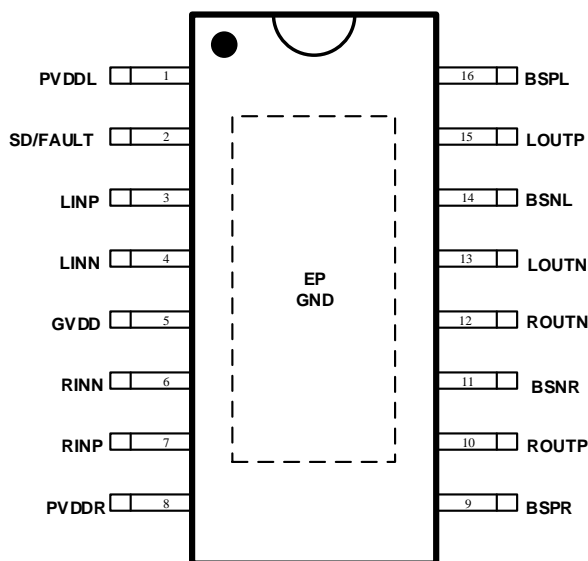
■ TERMINAL CONFIGURATION

HT326C Top View
■ TERMINAL FUNCTION

Terminal No.	Name	I/O ¹	Description
1	PVDDL	P	Power Supply for internal power circuitry of Channel L. 左声道功率电源
2	SD/FAULT	I	SD/FAULT, multi-function pin. When pulled down, place the speaker amplifier in shutdown mode. General fault reporting including Over-Temp, Over-Current, DC Detect. 接地时功放关闭。发生过温、过流、DC等保护时，该引脚拉低
3	LINP	I	Positive input terminal for L channel. 左声道输入正端
4	LINN	I	Negative input terminal for L channel. 左声道输入负端
5	GVDD	O	Voltage regulator derived from PVDD supply. 内部整流输出，接1uF电容到地
6	RINN	I	Negative input terminal for R channel. 右声道输入负端
7	RINP	I	Positive input terminal for R channel. 右声道输入正端
8	PVDDR	P	Power Supply for internal power circuitry of Channel R. 右声道功率电源
9	BSPR	BST	Connection point for the ROU TP bootstrap capacitor, which is used to create a power supply for the high-side gate drive for ROU TP. ROU TP自举电容位
10	ROU TP	O	Positive pin for differential speaker amplifier output R. 右声道输出正端
11	BSNR	BST	Connection point for the ROUTN bootstrap capacitor, which is used to create a power supply for the high-side gate drive for ROUTN. ROUTN自举电容位
12	ROUTN	O	Negative pin for differential speaker amplifier output R. 右声道输出负端
13	LOU TN	O	Negative pin for differential speaker amplifier output L. 左声道输出负端
14	BSNL	BST	Connection point for the LOU TLN bootstrap capacitor, which is used to create a power supply for the high-side gate drive for LOU TN. LOU TN自举电容位
15	LOU TP	O	Positive pin for differential speaker amplifier output L. 左声道输出正端
16	BSPL	BST	Connection point for the LOU TP bootstrap capacitor, which is used to create a power supply for the high-side gate drive for LOU TP. LOU TP自举电容位
EP	GND	G	Provides both electrical and thermal connection from the device to the Board, make sure it is connected to the system ground. 既是地，又是散热PAD

¹ I: Input; O: Output; G: Ground; P: Power; BST: BOOT Strap; OD: Open drain

■ SPECIFICATIONS¹
● Absolute Maximum Ratings²

PARAMETER	Symbol	MIN	MAX	UNIT
Supply voltage range (PVDD)		-0.3	22	V
Input voltage range (L1NP, L1NN, R1NP, R1NN, \SD)	V _I	-0.3	5.8	V
Operating temperature range	T _A	-40	85	°C
Operating junction temperature range	T _J	-40	150	°C
Storage temperature range	T _{STG}	-50	150	°C

● Recommended Operating Conditions

PARAMETER	Symbol	CONDITION	MIN	TYP	MAX	UNIT
Supply voltage range	V _{DD}	PVDD	4.5		20	V
Operating temperature	T _a		-40	25	85	°C
High-level input voltage	V _{IH}	\SD, Spread on	2.5		5.5	V
Middle-level input voltage	V _{IM}	\SD, Spread off	1.7		2.1	V
Low-level input voltage	V _{IL}	\SD			0.8	V
High-level input current	I _{IH}	\SD (V _I = 2V, V _{DD} = 12V)			1	uA
Low-level output voltage	V _{OL}	FAULT, OPEN-DRAIN OUTOUT			0.5	V
Load impedance (BTL)	R _L	With output filter	3.2	4		Ω
Load impedance (PBTL)	R _L	With output filter	1.6	2		Ω

● DC Electrical Characteristics

Conditions: T_A = 25°C, PV_{DD} = 4.5-20V, Load = 4ohm, unless otherwise specified.

PARAMETER	Symbol	CONDITION	MIN	TYP	MAX	UNIT
Class Output Offset Voltage	V _{OS}	V _I = 0V, Gain = 32dB		1.5		mV
Quiescent supply current	I _{DD}	V _{DD} = 12V, No Load		15		mA
Quiescent supply current in SD mode	I _{SD}	V _{DD} = 12V, With Load		12		uA
System Gain in BTL or PBTL mode	Gain	R _{in} = 0kΩ		32		dB
Turn-on time	t _{on}	Pull \SD high or power on		40		ms
Turn-off time	t _{off}	Pull \SD low		5		us
Gate drive supply	GVDD			5		V

¹ Depending on parts and PCB layout, characteristics may be changed.

² Stresses beyond those listed under absolute maximum ratings may cause permanent damage to the device. These are stress ratings only, and functional operation of the device at these or any other conditions beyond those indicated under recommended operating conditions is not implied. Exposure to absolute-maximum-rated conditions for extended periods may affect device reliability.

● **AC Electrical Characteristics**

Conditions: $T_A = 25^\circ\text{C}$, $V_{DD} = 4.5\text{-}20\text{V}$, Load = Filter + R_L , Filter = 300R Bead + 1nF, $R_L = 4\Omega + 22\mu\text{H}$, $f_{IN} = 1\text{ kHz}$, Gain = 26dB, $C_{IN} = 1\mu\text{F}$, 20-20kHz, unless otherwise specified.

PARAMETER	Symbol	CONDITION	MIN	TYP	MAX	UNIT	
Continuous output power	P_o	BTL, $V_{DD} = 12\text{V}$, $R_L = 4\Omega + 22\mu\text{H}$,	THD +N = 1%		14		W
			THD+N = 10%		17		W
		BTL, $V_{DD} = 12\text{V}$, $R_L = 8\Omega + 33\mu\text{H}$,	THD +N = 1%		8		W
			THD+N = 10%		10		W
Total harmonic distortion + noise	THD+N	$P_o = 1\text{W}$, $V_{DD} = 12\text{V}$, $R_L = 4\Omega$		0.05		%	
Efficiency	η	$V_{DD} = 12\text{V}$, THD+N = 10%	$R_L = 4\Omega$, BTL		88		%
			$R_L = 8\Omega$, BTL		93		%
Cross Talk	CT	$P_o = 1\text{W}$, Gain = 26dB		-100		dB	
Output integrated noise	V_N	A-weighted, Gain = 17.6 dB		75		μV	
Signal-to-noise ratio	SNR	A-weighted, Gain = 17.6 dB, $P_o = 1\text{W}$		88		dB	
Power supply rejection ratio	PSRR	200mVpp 1kHz, Input grounded		-75		dB	
Oscillator frequency	f_{osc}			360		kHz	
Spread frequency range				± 15		kHz	
Over temperature protection trigger point	OTP			150		$^\circ\text{C}$	
Over current trip point	OCP			7.5		A	

TYPICAL OPERATING CHARACTERISTICS

VDD = 12V, Load = 4ohm, unless otherwise specified.

V_{DD} vs I_{DD}

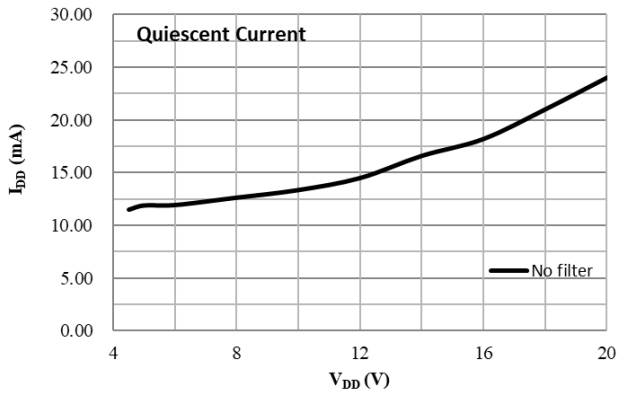

V_{DD} vs I_{SD}

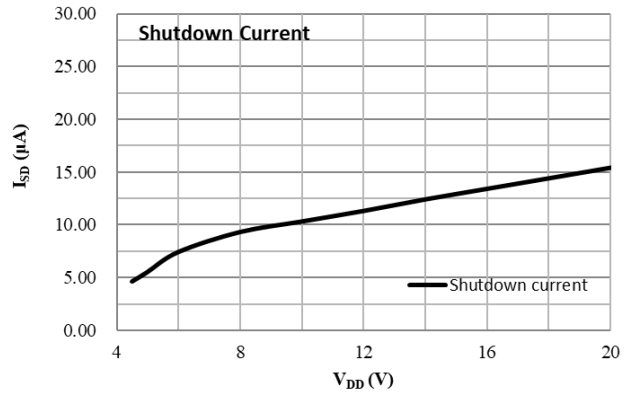

V_{DD} vs P_O

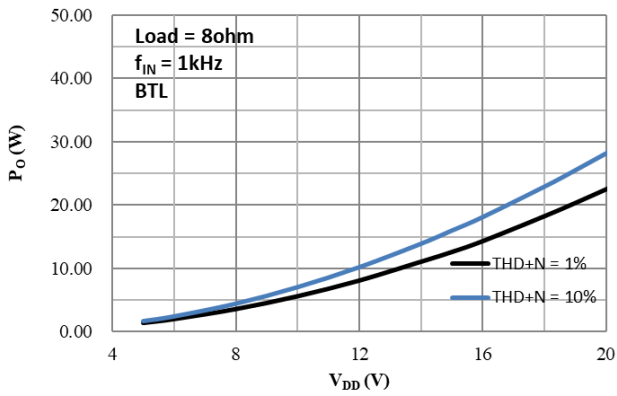

V_{DD} vs P_O

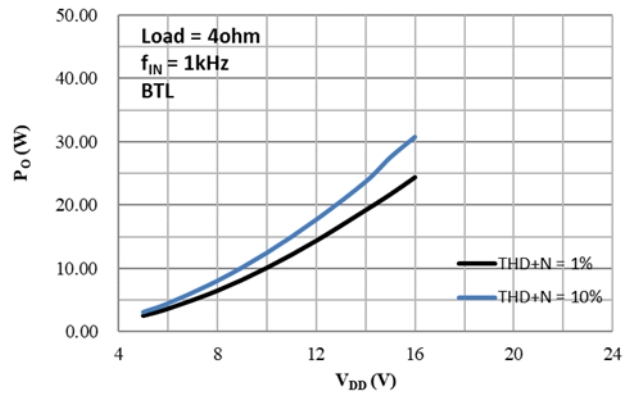

V_{DD} vs P_O

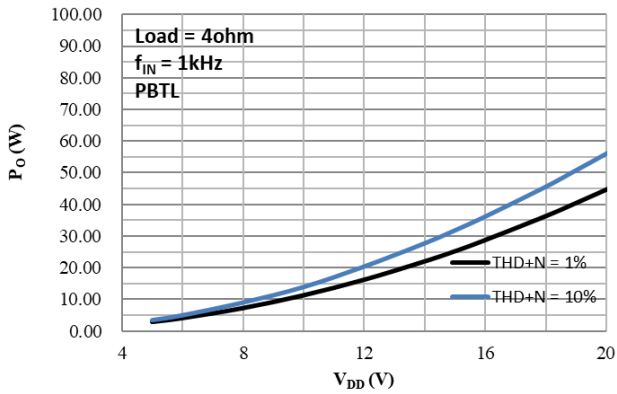

P_O vs η

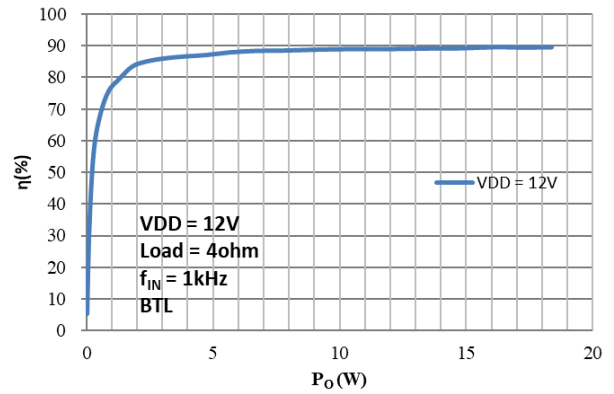

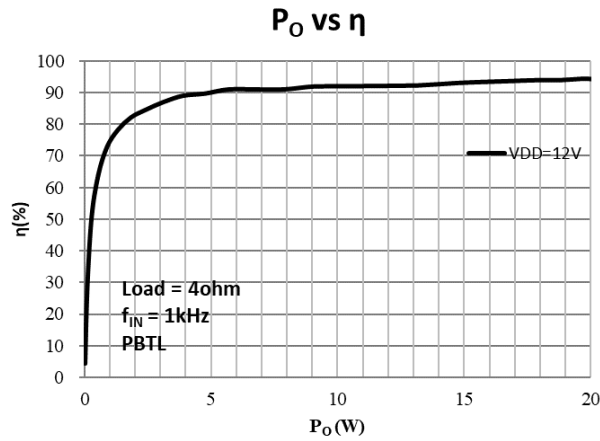

Audio Precision

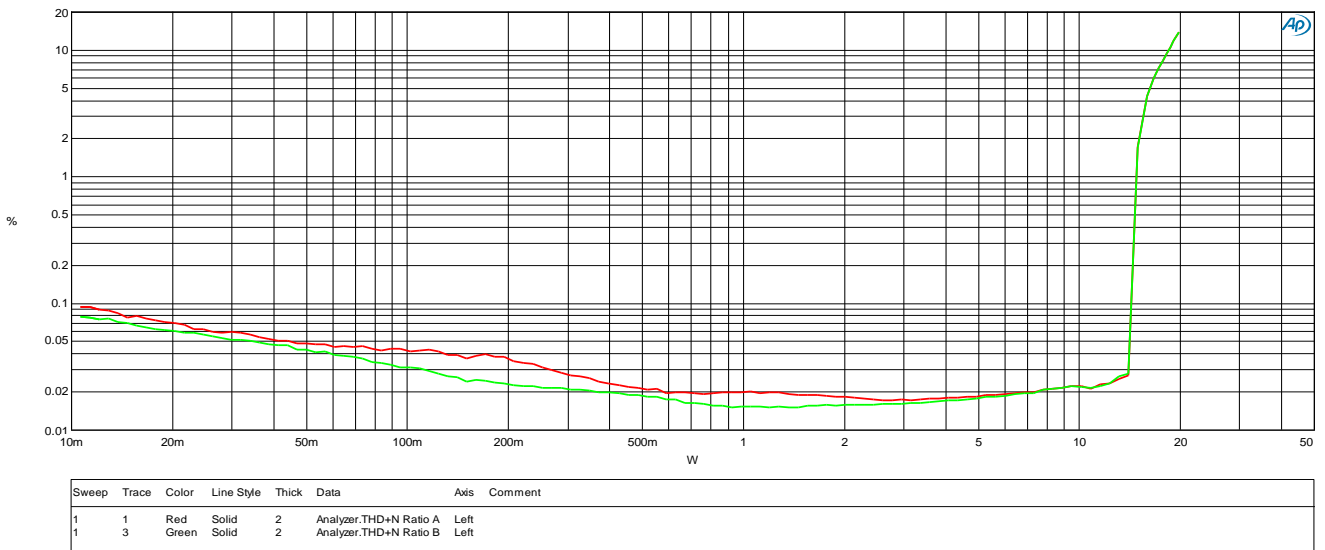

A-A FFT.ats2
VDD = 12V, Load = 4ohm, f_{IN} = 1kHz, Spread Spectrum on,

Audio Precision

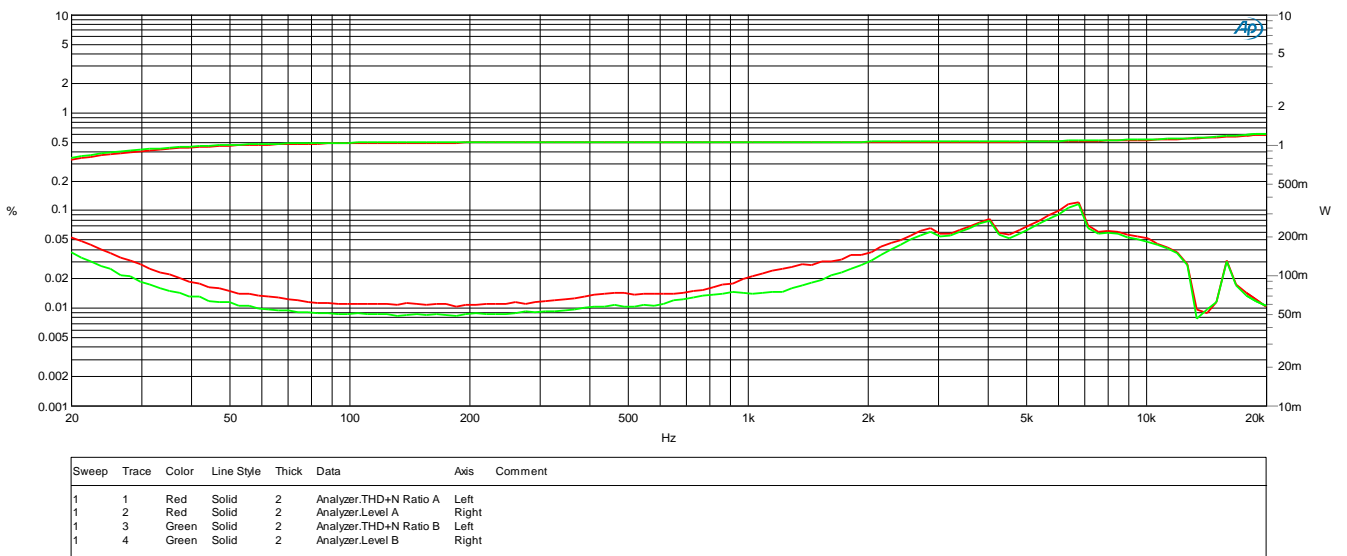

A-A FFT.ats2
VDD = 12V, Load = 4ohm, P_O = 1W, Spread Spectrum on,

APPLICATION INFORMATION

1 Power Supplies

The power supply for the HT326C only requires one voltage from 4.5V to 20V, which supplies the analog circuitry and the power stage.

GVDD is the LDO output derived from PVDD, and it should connect a filtering capacitor 1uF.

Filtering capacitors of 100nF//1uF//220uF for PVDD should be placed close to the PVDD pin..

HT326C 仅需要一种电源供电，即在 PVDDL 和 PVDDR 端加 4.5~20V。PVDD 端建议各加 100nF//1uF//220uF 的并联电容到地。

GVDD 是 LDO 输出，接 1uF 电容到地进行滤波。

2 Amplifier Input and Output

HT326C is an amplifier with analog input (single-ended or differential).

For a differential operation, input signals into INP and INN pins via DC-cut capacitors (C_{IN}). The high pass cut-off frequency of input signal can be calculated by

$f_c = \frac{1}{2\pi(\text{External } R_{IN} + \text{Internal } R_{IN}) \times C_{IN}}$. The input signal gain is calculated by $A_v \approx \frac{R_F}{\text{External } R_{IN} + \text{Internal } R_{IN}}$. The $R_F=370k$, internal $R_{in}=9.6k$.

For a single-ended operation, input signals to INP pin via a DC-cut capacitor (C_{IN}). INN pin should be connected to ground via a DC-cut capacitor (with the same value of C_{IN}).

HT326C 接受模拟差分或单端音频信号输入，产生 PWM 脉冲输出信号驱动扬声器。

对差分输入，通过隔直电容 C_{IN} 和输入电阻 R_{IN} 分别输入到 INP 和 INN 端。系统增益 $A_v \approx \frac{R_F}{\text{External } R_{IN} + \text{Internal } R_{IN}}$ ， $R_F=370k$ ，internal $R_{in}=9.6k$ 。高通滤波器截止频率为 $f_c = \frac{1}{2\pi(\text{External } R_{IN} + \text{Internal } R_{IN}) \times C_{IN}}$ 。

对单端输入，则通过 C_{IN} 耦合到 INP 端。INN 端必须通过输入电阻和电容（与 C_{IN} 、 R_{IN} 值相同）接地。增益 A_v 和截止频率 f_c 与差分输入时相同。

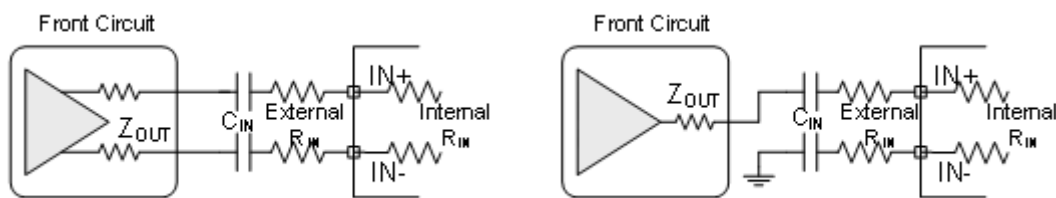

Figure 1 (1) Differential Input;

(2) Single-ended Input

3 Output Configuration

HT326C can directly drive speakers without any other components. But if EMI is highly concerned, ferrite beads or L-C filter is needed.

一般而言，输出端可直接连接负载喇叭。如对 EMI 的要求较高，则可选择添置铁氧体磁珠或 LC 滤波器。

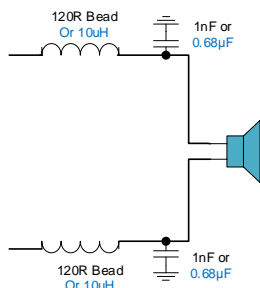

Figure 2 Output Configuration

4 PBTB Mode Configuration

The HT326C can be configured to drive a single speaker with the two output channels connected in parallel which is called Parallel Bridge Tied Load (PBTB) mode. When operated in PBTB mode, the output pins and input pins should be connected as following, and the amplifier accepts its source signal from the R channel of the stereo signal.

HT326C可配置再单声道输出的PBTB模式，其连接方式如下图，此时音频信号从右通道输入。

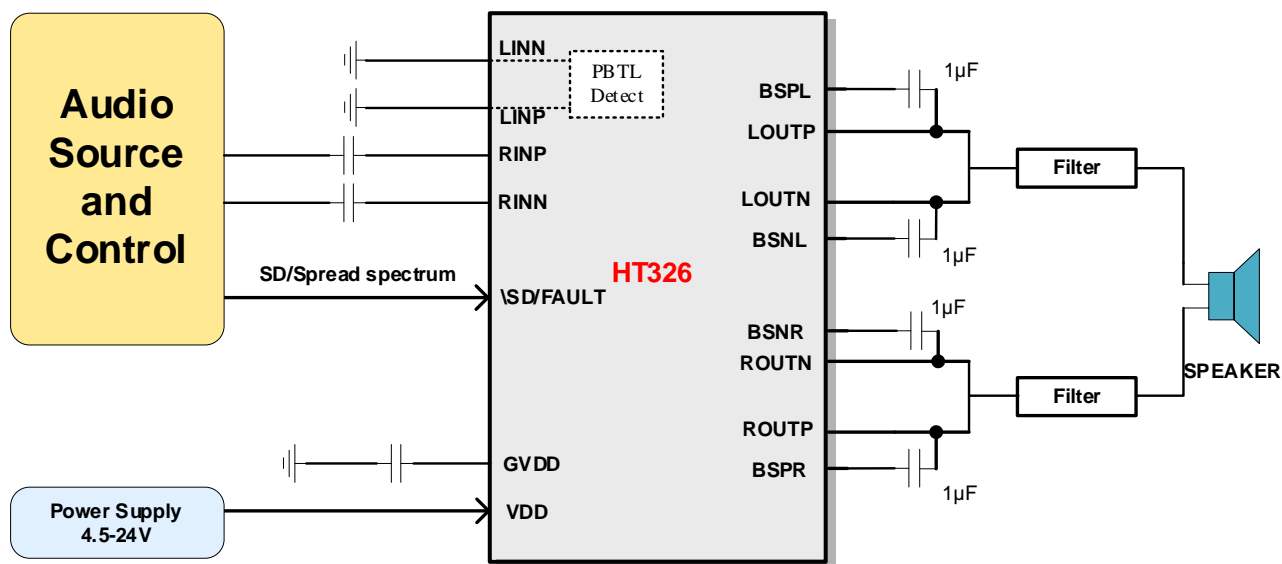

Figure 3 PBTB Mode Configuration

5 Startup, Shutdown

The HT326C employs a shutdown mode of operation designed to reduce supply current (I_{DD}) to the absolute minimum level during periods of nonuse for power conservation. The \SD input terminal should be held high during normal operation when the amplifier is in use. Pulling \SD low will put the outputs to mute and the amplifier to enter a low-current state. It is not recommended to leave \SD unconnected and pull \SD down less than 100us, because amplifier operation would be unpredictable.

HT326C具有关断功能，以使芯片进入低功耗状态。当\SD拉高时，芯片进入工作状态；当\SD拉低时，芯片进入关断状态。

\SD不建议悬空，也不建议\SD低电平的状态小于100us，否则可能状态不定。

上下电时，为减小pop声，在上、下电前，将功放关闭进入关断状态。

For a better power on and power-off pop performance, place the amplifier in the shutdown mode prior to delivering or removing the power supply..

6 Spread Spectrum

The HT326C device has built-in spread spectrum control of the oscillator frequency to improve EMI performance. The spread spectrum scheme is internally fixed. It can be disabled by pulling up \SD terminal into 1.7~2.1V.

HT326C 内置了输出频率的扩频功能，以提升EMI性能。其可通过将\SD脚上拉到1.7~2.1V来关闭。

7 GVDD Supply

The GVDD Supply is used to power the gates of the output full bridge transistors. Decouple GVDD with a 1 µF capacitor to GND. The GVDD supply is not intended to be used for external supply.

GVDD 电源用于为输出全桥晶体管的栅极供电。使用 µF 电容器将 GVDD 与 GND 连接。GVDD 电源不用于外部电源。

8 BSP and BSN Capacitors

A 1uF ceramic capacitor must be connected from each output to its corresponding bootstrap input (BSP and BSN).

9 Protection Function

HT326C has the protection functions such as Over-Current Protection function, Thermal Protection function, and over voltage protection.

(1) Over-current Protection function (OCP)

When a short circuit occurs on the output stage, the over-current protection mode starts up. In the over current protection mode, the differential output terminal becomes a high impedance state. The Over-current Protection fault is reported on the SD/FAULT pin as a low state.

(2) Thermal Protection function (OTP)

When excessive high temperature of HT326C (150°C) is detected, the thermal protection mode starts up. In the thermal protection mode, the differential output terminal becomes Weak Low state (a state grounded through high impedance), and the SD/FAULT pin is pulled low..

(3) DC Detect Protection. (DCP)

The HT326C has circuitry which will protect the speakers from DC current which might occur due to an internal amplifier error. The DC Detect fault will cause the amplifier to shutdown by changing the state of the outputs to Hi-Z, and will be reported on the \SD pin as a low state.

A DCE event occurs when the output differential duty-cycle of either channel exceeds 60% for more than 420 msec at the same polarity. This feature protects the speaker from large DC currents or AC currents less than 2 Hz.

When OCP, OTP or DCP is activated, the SD/FAULT pin will be pulled low, and the error signal will be cleared. Therefore, after a delay time (normal 1.3s), HT326C will try restart.

(3) Under-Voltage Protection (UVP)

This is the function to establish the under-voltage protection mode when power supply becomes lower than the detection voltage VUVLL (Typ. 4.2V), and the protection mode is canceled when the power supply becomes higher than the threshold voltage VUVLH (Typ. 4.4V). In the under-voltage protection mode, the differential output pin becomes weak low state (a stage grounded through resistivity). HT326C will start up within start-up time when the under-voltage protection mode is cancelled.

(4) Over-voltage Protection function

The HT326C device monitors the voltage on AVCC voltage. When the voltage on AVCC pin exceeds the over-voltage threshold (28V typ), the OVP circuit puts the device into shutdown mode. The device recovers automatically once the over-voltage condition has been removed.

在 BSx 引脚和相应输出之间,需要添加 1uF 自举电容器,用作高端 NMOS 栅极驱动电路的电源。

HT326C 具有以下几种保护功能: 输出端过流保护、片内过温保护、升压过压保护。

(1) 过流保护

当检测到输出端短路时,过流保护启动,输出端切换至高阻态,防止芯片烧毁损坏,SD/FAULT 脚被拉低。

(2) 过温保护

当检测到芯片内温度超过 150°C 时,过温保护启动,正负输出端切换至弱低电平状态(内部通过高阻接地),防止芯片被热击穿损坏,SD/FAULT 脚被拉低。

(3) 直流监测保护

HT326C 具有保护扬声器免受由于内部放大器错误而产生的直流电流影响的电路。直流检测故障时,输出状态更改为 Hi-Z,致放大器关闭。另外,\SD 引脚被拉低

当任一通道在相同极性下的输出差占空比超过 60%超过 420 毫秒时,就会发生 DCE 事件。此功能可保护扬声器免受大直流电流或小于 2 Hz 的交流电流的影响。

当 OCP, OTP, DCP 被触发,SD 脚会被下拉,从而错误状态被清除,因此经过一个延迟时间(1.3s),HT326C 将重启。

(3) 欠压保护

当电源电压低于 VUVLL (Typ. 4.2V)时,HT326C 进入欠压保护状态;当电源电压高于 VUVLH (Typ. 4.4V),芯片退出欠压保护。在欠压保护状态下,输出通过电阻下拉到地;退出欠压保护时,需要经过启动时间。

(4) 过压保护

HT326C 监控 PVDD 电压上的电压。当 PVDD 引脚上的电压超过过电压阈值(28V 典型值)时,OVP 电路将 HT326C 置于关机模式。一旦消除过电压情况,设备将自动恢复。

10 Typical Circuit Diagram

SD	MODE
<0.8V	SD
1.8V-2.2V	SPREAD OFF
>2.4V	SPREAD ON

JP7+JP8

JP7

GAIN	
Fixed at	32dB

MODE	
Fixed at	Hybrid

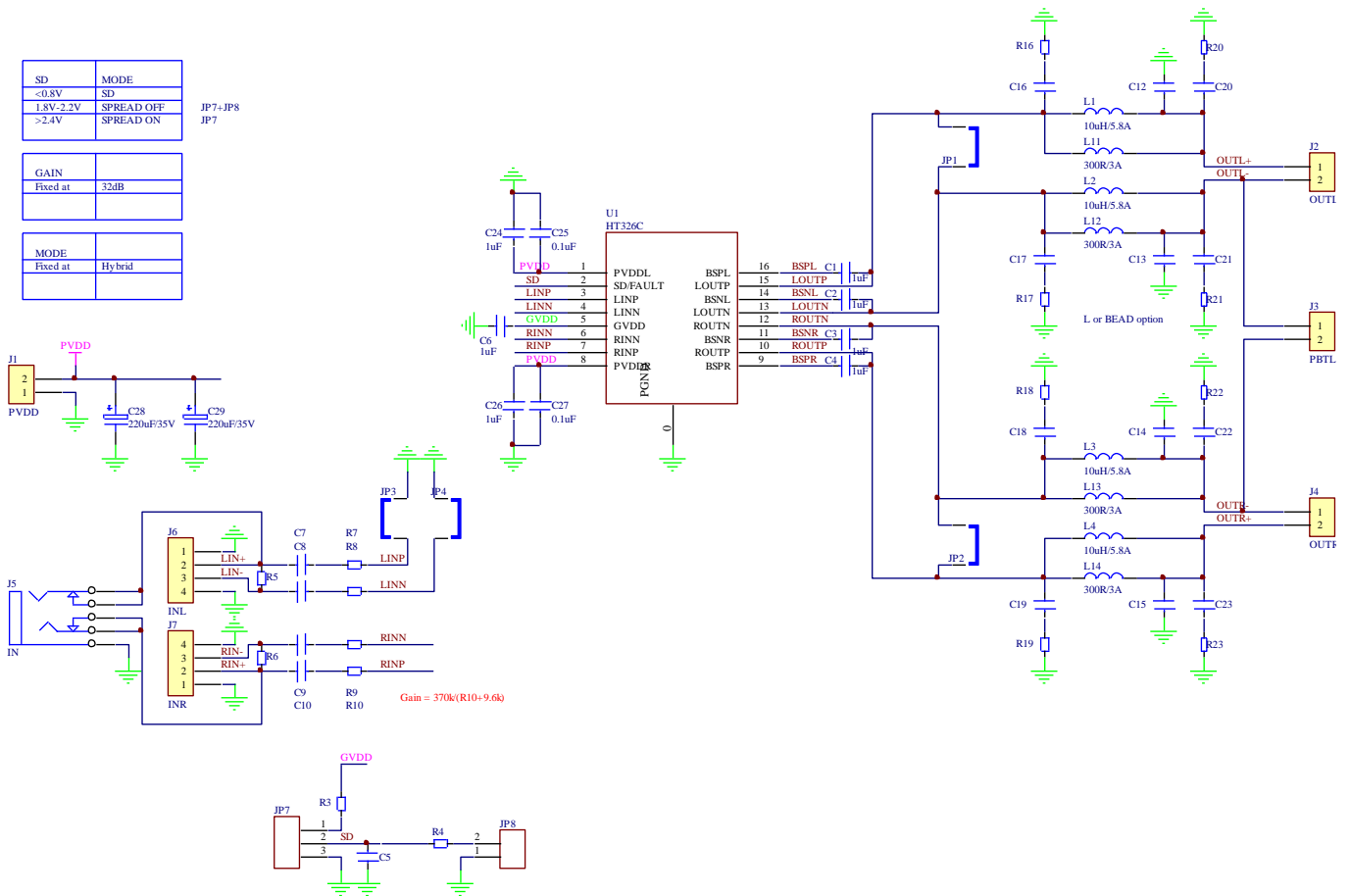

11 PCB Layout

11.1 Top Layer

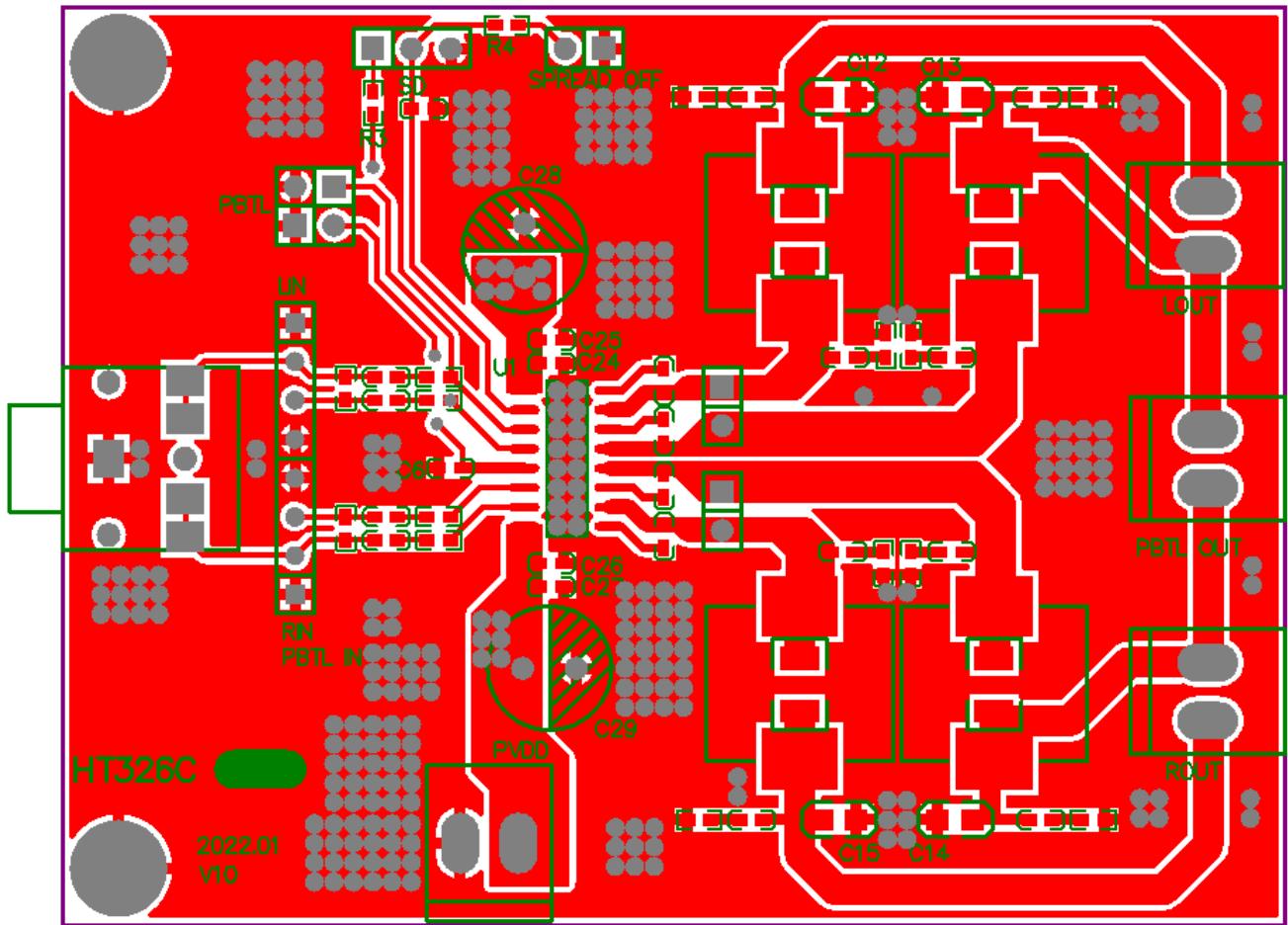

11.2 Bottom Layer

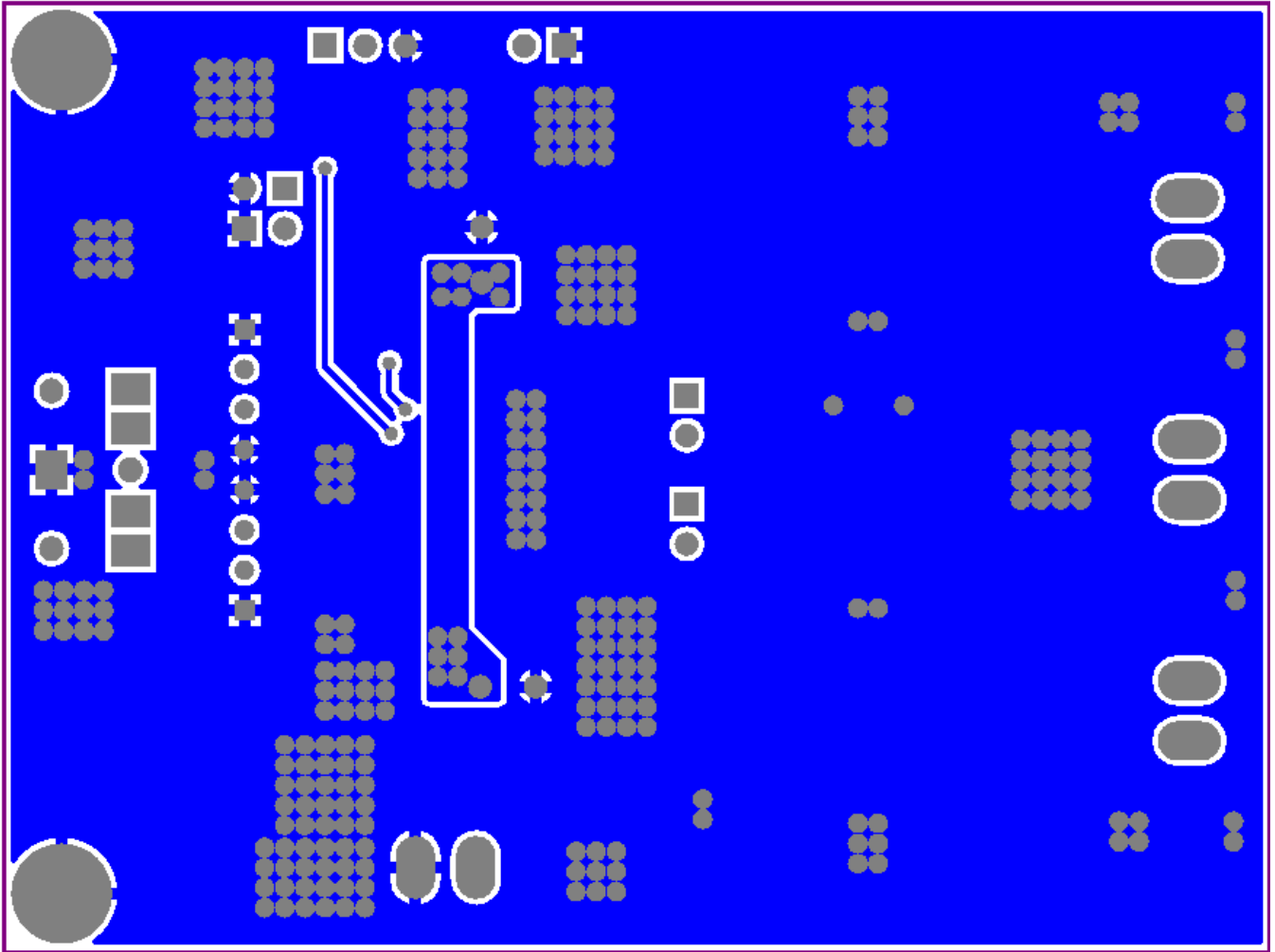

PACKAGE OUTLINE

SPE (ESOP16)

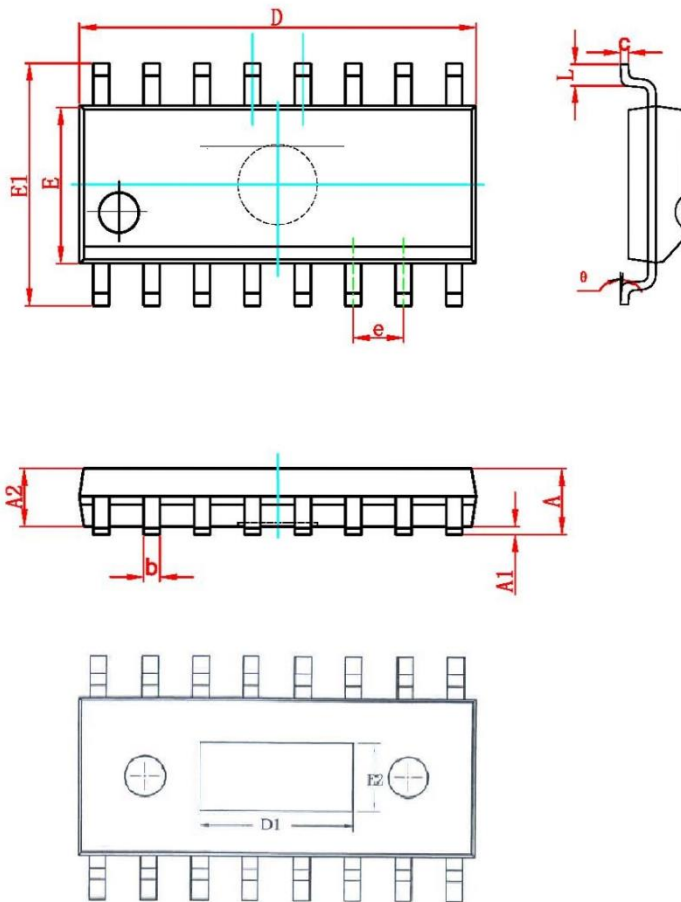

Symbol	Size (mm)	
	MIN	MAX
A	-	1.75
A1	0.05	0.15
A2	1.30	1.50
b	0.39	0.48
c	0.21	0.26
D	9.70	10.10
D1	4.57(REF)	
E	3.70	4.10
E1	5.80	6.20
E2	2.41(REF)	
e	1.27(BSC)	
L	0.50	0.80
θ	0°	8°

IMPORTANT NOTICE**注意**

Heroic Electronic Technology (Jiaxing) Co., Ltd (HT) reserves the right to make corrections, modifications, enhancements, improvements, and other changes to its products and services at any time and to discontinue any products or services. Customers should obtain the latest relevant information before placing orders and should verify that such information is current and complete.

禾润电子科技（嘉兴）股份有限公司（以下简称HT）保留对产品、服务、文档的任何修改、更正、提高、改善和其他改变，或停止提供任何产品和服务的权利。客户在下单和生产前应确保所得到的信息是最新、最完整的。

HT assumes no liability for applications assistance or customer product design. Customers are responsible for their products and applications using HT components.

HT对相关应用的说明和协助以及客户产品的板级设计不承担任何责任。

HT products are not authorized for use in safety-critical applications (such as life support devices or systems) where a failure of the HT product would reasonably be expected to affect the safety or effectiveness of that devices or systems.

HT的产品并未授权用于诸如生命维持设备等安全性极高的应用中。

The information included herein is believed to be accurate and reliable. However, HT assumes no responsibility for its use; nor for any infringement of patents or other rights of third parties which may result from its use.

本文中的相关信息是精确和可靠的，但HT并不对其负责，也不对任何可能的专利和第三方权利的侵害负责。

Following are URLs and contacts where you can obtain information or supports on any HT products and application solutions:

下面是可以联系到我公司的相关链接和联系方式：

禾润电子科技（嘉兴）股份有限公司
Heroic Electronic Technology (Jiaxing) Co., Ltd.

地址：浙江省嘉兴市凌公塘路3339号JRC大厦A座三层

Add: A 3rd floor, JRC Building, No. 3339, LingGongTang Road, Jiaxing, Zhejiang Province

Sales: 0573-82585539, sales@heroic.com.cn

Support: 0573-82586151, support@heroic.com.cn

Fax: 0573-82585078

Website: www.heroic.com.cn; wap.heroic.com.cn

Wechat MP: HEROIC_JX

请及时关注禾润官方微信公众号，随时获取最新产品信息和技术资料！

